

roller shutters  
and exterior blinds



EFFEZETA®  
SYSTEM

Live protected. Live better.



EFFEZETA®  
SYSTEM  
**Vivi protetto. Vivi meglio.**

# index

- 06 our company**
- 10 product map**
- 10 insulated aluminium**
- 10 extruded aluminium**
- 10 insulated steel**
- 10 plus**
- 11 adjustable products**
- 11 safety**
- 11 pvc**
  - Top seller**
- 14 aluminium 12**  
insulated aluminium
- 16 aluminium 09**  
insulated aluminium
- 18 airlux**  
luce plus
- 20 airlux combined**  
luce plus, alluminio e pvc
- 22 orienta**  
adjustable roller shutter
- 24 double safe**  
anti-burglary roller shutter
- 26 visionplus**  
extruded aluminium
- 28 shutter boxes and monoblocs**
- 32 exterior blinds**
- 34 download catalogues**



## Our company

EffeZeta System was founded in 1999 as a simple craft in a small village in southern Italy, Sant'Angelo d'Alife (Caserta). Today the company presents itself as a large industrial reality, competitive on the market both nationally and internationally. The company has evolved over time, always operating with the same conviction: feeling comfortable in the space where you live or work is fundamental to live it to the fullest.

That's why our goal is to provide design products that are able to meet the needs of each person and adapt to the most diverse environments. We constantly invest in research and development, to continue to ensure the best and keep up with the continuous changes that, with increasing frequency, affect everyday life.

*Today's great enterprises yesterday were only small ideas carried out with courage and tenacity.*

## Vision

For over 20 years, EffeZeta System has pursued a single goal: to offer modern and functional design solutions to improve the quality of life of people.

## Mission

We are specialized in insect, animal, pollen, sun and heat protection systems. In particular, we produce flyscreens, roller shutters, exterior blinds and other shading systems.



### Made in Italy

Our Made in Italy, particularly appreciated by international customers, is synonymous with guarantee and quality.



### Safety



Safety, understood as protection from insects, pollen, sun and heat, is our ability to offer a product that increases the level of well-being of anyone.

### Know how



We put in place a highly qualified, young, dynamic and up-to-date work team in every sector of the company: from production, to logistics, to the sales network, to customer service.

### Sustainability



Our products are sustainable. Aluminium is a 100% and infinitely recyclable raw material. In our plants the machines are electric and support photovoltaic systems.

### Sales network capillary in Italy

- 6 production sites in Campania
- 1 production site in Lombardy
- 1 production site in Lazio

## Why should people choose EffeZeta System?

- Customized products
- Different product versions
- Multiple colors available
- Customized solutions
- Repair service
- Smart and motorized products
- Free quotes
- Products tested one by one
- Customer service
- Short delivery times
- Extensive commercial network
- Cutting-edge technologies

### Research and innovation



We have specialized consultants who work intensively in research and experimentation to offer solutions that are increasingly innovative and able to respond to the challenges of the future.

### EffeZeta System international



For years the company has consolidated its presence internationally through the development of business relations, especially in Europe, Africa and America. Today we have a sales office in Dubai

### Certified quality



All our products have the European Conformity Mark (CE) that guarantees the consumer the conformity of the product with the provisions of the European Community throughout the production cycle.

Istituto Giordano is a leading Technical Body in the testing of Product, Certification, Research and Design that deals with the certification of our products.

Legnolegno is the Italian consortium of window manufacturers: being associated means being part of a large chain of companies in the window industry.



**insulated aluminium**



Insulated aluminium roller shutters in ecological polyurethane foam: a lightweight and resistant material that guarantees high stability, long life. The product does not need any maintenance because it is resistant to abrasion, to polluting and atmospheric agents, to cold and heat.

**extruded aluminium**



Roller shutters in extruded aluminium high stability and long life: Their advantage is to remain effective without any maintenance.

**insulated steel**



Insulated steel roller shutters in ecological polyurethane foam: a lightweight and resistant material that guarantees high stability, long life. The product does not need any maintenance because it is resistant to abrasion, pollutants and atmospheric agents, cold and heat.

**plus**

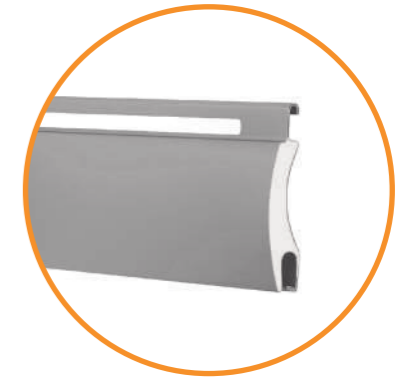

Insulated aluminium roller shutters in ecological polyurethane foam with slats with wide or combined slots in aluminium and PVC that allow to reduce the waste of economic and energy resources by acting on the thermal conductivity of the metal.

**Types of slats available**

**aluminium 12**    **aluminium 09**

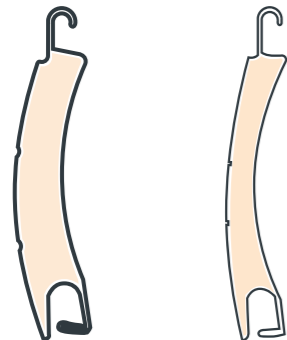

**12,8 x 55 mm**    **9,3 x 45 mm**  
Medium density    Medium density  
High density    High density

**flat**    **zero**

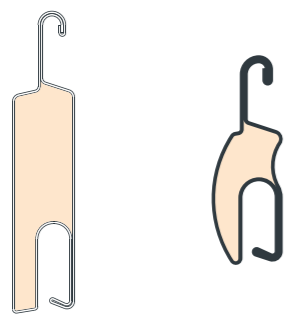

**8,5 x 30 mm**    **12,8 x 55 mm**  
Medium density    High density  
High density    Microperforated  
Large buttonhole    Standard buttonhole

**Types of slats available**

**estruso 13**    **estruso 7 microforato**

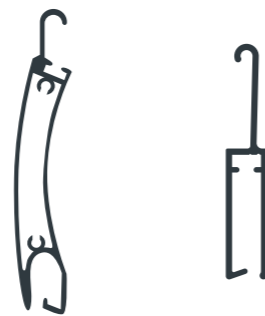

**13 x 55 mm**    **7,6 x 43,2 mm**

**airdouble**    **visionplus**

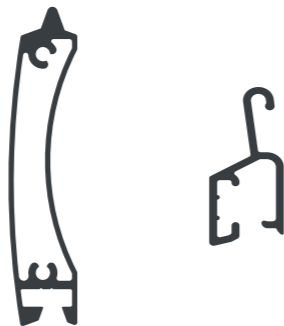

**13 x 55 mm**    **10 x 8,5 mm**

**Types of slats available**

**steel 12**    **steel 09**

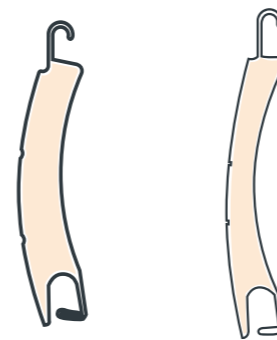

**12 x 55 mm**    **9,3 x 45 mm**  
High density    Medium density

**Types of slats available**

**airlux**    **aizanzar**    **combined 55**

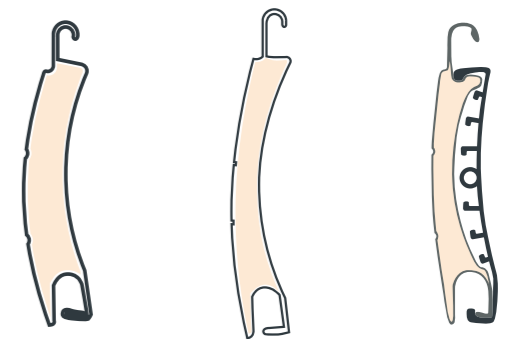

**12 x 55 mm**    **9,3 x 45 mm**    **12 x 55 mm**

**combined 40**    **airlux combined**

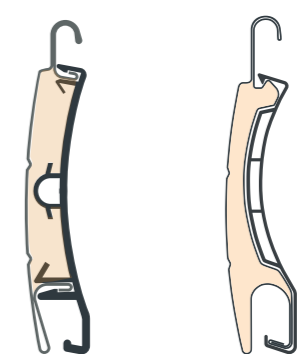

**9,3 x 45 mm**    **9,3 x 45 mm**

**adjustable**

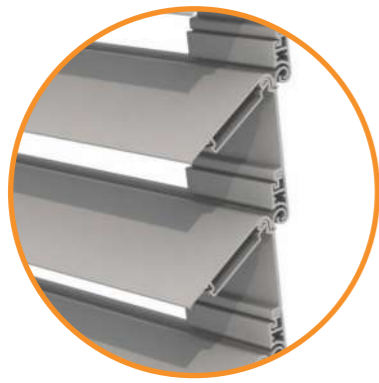

Oriente is the roller shutter system with adjustable slats, a perfect combination of roller shutter and shutter. It allows you to ventilate, illuminate and protect from the sun, safely.

**safety**



Extruded aluminium roller shutters with special interlocking systems and inserts that guarantee greater safety from external intrusions.

**pvc**



Pvc roller shutters made of self-attaching slats with side stop anti-filament that blocks the slats. Resistant to cold and heat.

**serrande**



Insulated aluminium roller shutters with eco-friendly polyurethane foam. Product with high stability and long life, without any maintenance.

**Types of slats available**

**orienta**

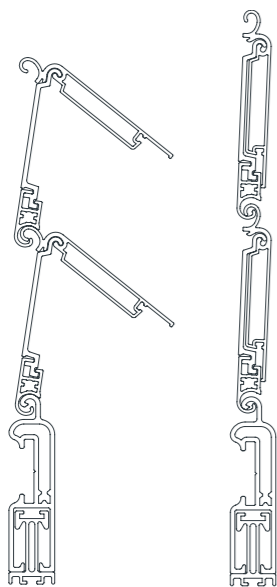

11,17 x 63,5 mm

**Types of slats available**

**safe roller**

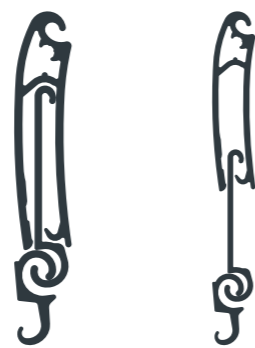

9,3 x 54 ca. mm

**double safe**



9,3 x 45 mm

**Types of slats available**

**napoli**



13 x 55 mm

**capri**



13 x 55 mm

**ischia**



14 x 50 mm

**mignon**



9 x 38 mm

**Types of slats available**



19 x 77 mm



## aluminium 12

INSULATED ALUMINIUM ROLLER SHUTTER  
MEDIUM AND HIGH DENSITY

Insulated aluminium roller shutters in ecological polyurethane foam: a lightweight and resistant material that guarantees high stability, long life. The product does not need any maintenance because it is resistant to abrasion, to polluting and atmospheric agents, to cold and heat.

<b>Profile size</b>	12,8 x 55 mm
<b>Weight per sqm</b>	Medium density approx. 2,93 kg High density approx. 3,95 kg
<b>Aluminium thickness</b>	Approx. 0,27 mm



### Stoppers cup for slats

Rolling diameter	Roller Ø 60 (mm)		Profile
	H	Ø	
	1000	160	
	1200	160	
	1400	180	
	1600	180	
	1800	190	
	2000	200	
	2200	200	
	2400	210	
	2600	230	
	2800	230	
	3000	240	
	3200	240	
	3400	250	
	3600	260	
	3800	260	
	4000	270	
	4200	270	
	4400	280	
	4600	290	

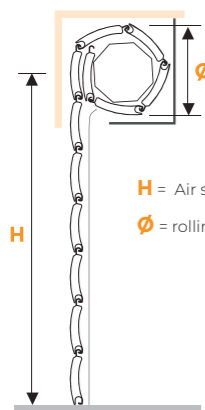

H = Air space measurement  
Ø = rolling diameter

### Compatible guides, terminals and accessories

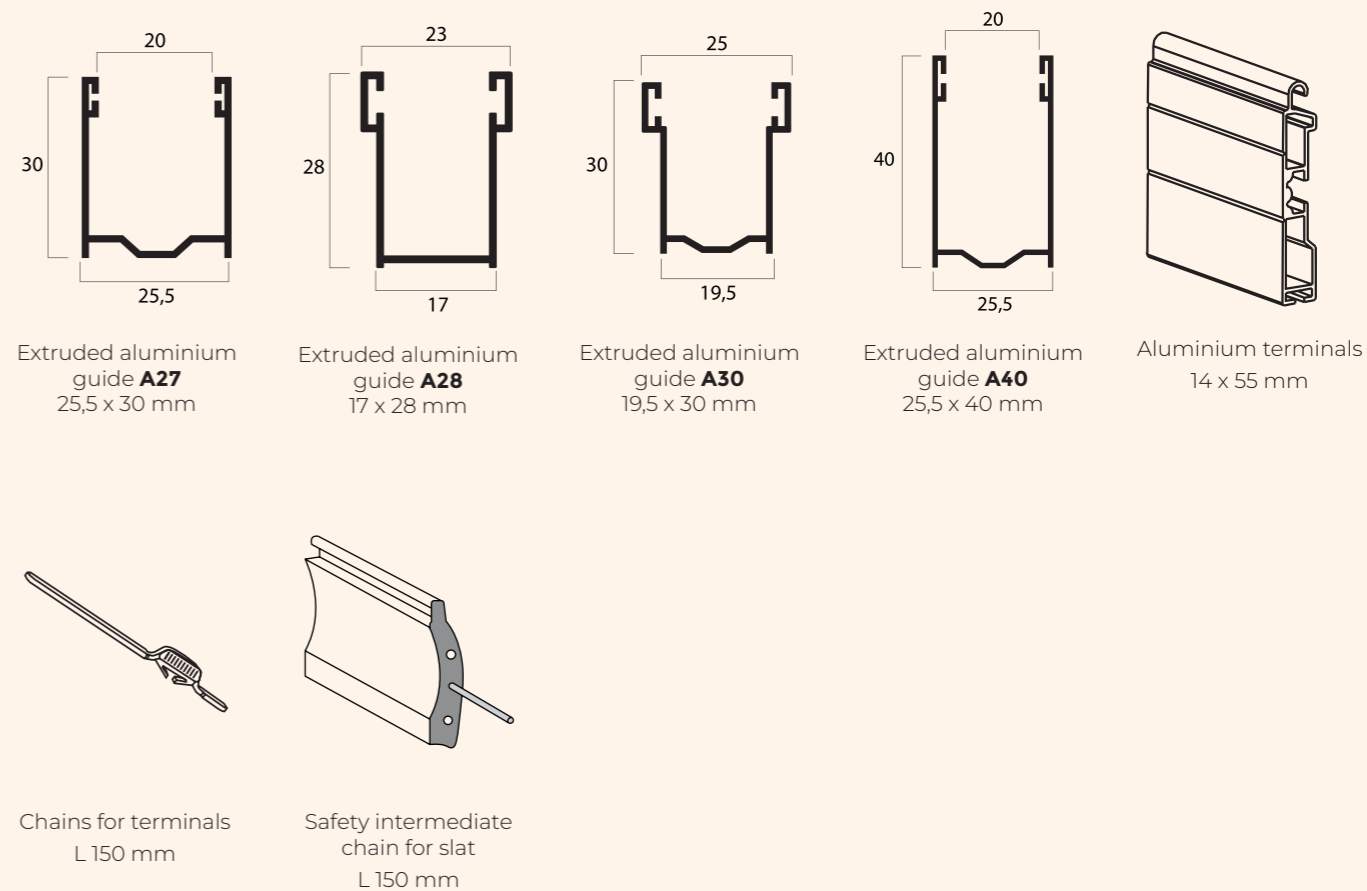

Chains for terminals  
L 150 mm

Safety intermediate  
chain for slat  
L 150 mm

### Colors

Category	Color Name	Color Name	Color Name	Color Name	Color Name	Color Name	Color Name	Color Name	Color Name	
Ral	1 Bianco*	2 Argento	3 Grigio	36 Grigio 35*	46 Grigio medio	42 Grigio 7016	8 Avorio	21 Marrone cioccolato*	7 Testa di moro*	
	5 Verde*									
	Special	45 Bianco papiro*	19 Panna*	4 Beige	32 Sabbia	26 Ocra	25 Terracotta*	47 Ral 7001	15 Azzurro*	33 Verde acqua
		13 Verde brillante	6 Rosso mat-tone	16 Bordeaux 3005**	22 Verde Raffaello	23 Marrone Raffaello	24 Grigio Raffaello*			
		Wood	10 Legno chiaro	11 Legno scuro	37 Legno castagno	39 Legno noce	34 Legno pino	62 renolit bianco		

\*available for high density  
\*\*not available for medium density

The best possible representation of colors has been reported in our collection. Differences between these colors and the colors of the samples are not disputed.





## aluminium 09

INSULATED ALUMINIUM ROLLER SHUTTER  
MEDIUM AND HIGH DENSITY

Insulated aluminium roller shutters in ecological polyurethane foam: a lightweight and resistant material that guarantees high stability, long life. The product does not need any maintenance because it is resistant to abrasion, to polluting and atmospheric agents, to cold and heat. The slim design ensures smaller footprint with the same strength.

<b>Profile size</b>	9,3 x 45 mm
<b>Weight per sqm</b>	Medium density approx 2,12 Kg High density approx. 2,65 kg
<b>Aluminium thickness</b>	Approx. 0,23 mm

Rolling diameter	Roller Ø 40 (mm)		Roller Ø 60 (mm)		Profile
	H	Ø	H	Ø	
1000	120	120	1000	125	
1200	135	120	1200	135	
1400	135	140	1400	140	
1600	140	160	1600	150	
1800	150	180	1800	155	
2000	155	200	2000	160	
2200	155	2200	2200	165	
2400	170	2400	2400	170	
2600	170	2600	2600	175	
2800	175	2800	2800	180	
3000	180	3000	3000	185	
3200	185	3200	3200	190	
3400	185	3400	3400	195	
3600	190	3600	3600	200	
3800	200	3800	3800	200	
4000	205	4000	4000	205	
4200	205	4200	4200	210	
4400	210	4400	4400	210	
4600	215	4600	4600	220	

H = Air space measurement  
Ø = rolling diameter

### Compatible guides, terminals and accessories

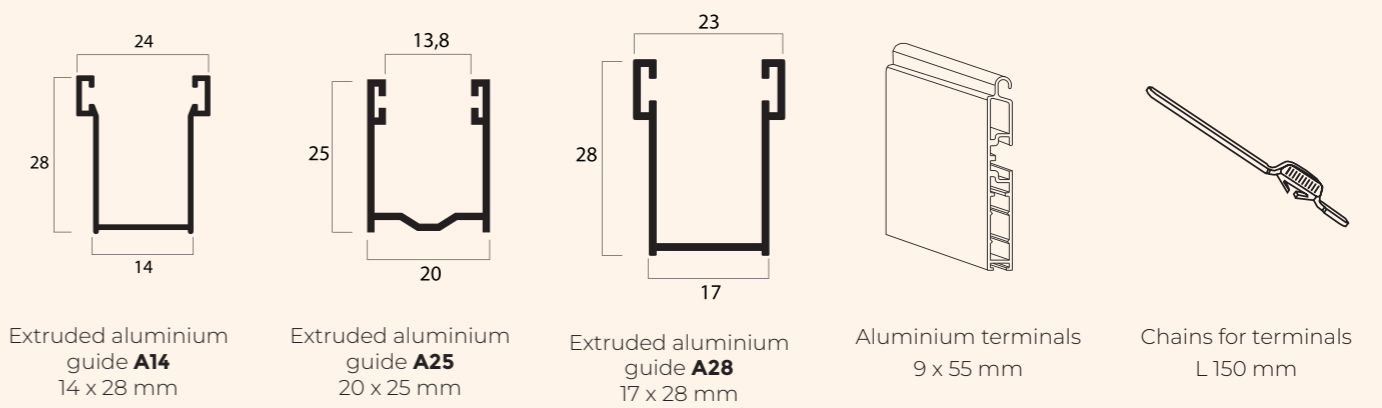

### Colors

Color	Code
1 Bianco*	1 Bianco*
2 Argento	2 Argento
3 Grigio	3 Grigio
36 Grigio 35*	36 Grigio 35*
46 Grigio medio	46 Grigio medio
42 Grigio 7016	42 Grigio 7016
8 Avorio	8 Avorio
21 Marrone cioccolato*	21 Marrone cioccolato*
7 Testa di moro*	7 Testa di moro*
5 Verde*	5 Verde*
45 Bianco papiro*	45 Bianco papiro*
19 Panna*	19 Panna*
4 Beige	4 Beige
32 Sabbia	32 Sabbia
26 Ocra	26 Ocra
25 Terracotta*	25 Terracotta*
47 Ral 7001	47 Ral 7001
15 Azzurro*	15 Azzurro*
33 Verde acqua	33 Verde acqua
13 Verde brillante	13 Verde brillante
6 Rosso mat-tone	6 Rosso mat-tone
16 Bordeaux 3005**	16 Bordeaux 3005**
22 Verde Raffaello	22 Verde Raffaello
23 Marrone Raffaello	23 Marrone Raffaello
24 Grigio Raffaello*	24 Grigio Raffaello*
10 Legno chiaro	10 Legno chiaro
11 Legno scuro	11 Legno scuro
37 Legno castagno	37 Legno castagno
39 Legno noce	39 Legno noce
34 Legno pino	34 Legno pino
62 renolit bianco	62 renolit bianco

\*available for high density  
\*\*not available for medium density

The best possible representation of colors has been reported in our collection. Differences between these colors and the colors of the samples are not disputed.



### airlux

INSULATED STEEL ROLLER SHUTTER WITH LARGE BUTTONHOLE AND MEDIUM OR HIGHT DENSITY POLYURETHANE

Airlux is an insulated aluminium roller shutter with a significantly wider loop than standard models. This feature allows, when the roller shutter is lowered, greater and ambient lighting.

<b>Profile size</b>	12 x 50 mm
<b>Weight per sqm</b>	Medium density approx 5,00 Kg High density approx. 6,00 kg
<b>Aluminium thickness</b>	Approx. 0,50 mm

Standard Buttonhole



Airlux Buttonhole



Rolling diameter	Roller Ø 60 (mm)		Profile
	H	Ø	
	1000	145	
	1200	155	
	1300	155	
	1400	160	
	1500	170	
	1600	170	
	1700	175	
	1800	180	
	1900	190	
	2000	190	
	2200	200	
	2400	205	
	2600	210	
	2800	220	
	3000	230	
	3300	240	

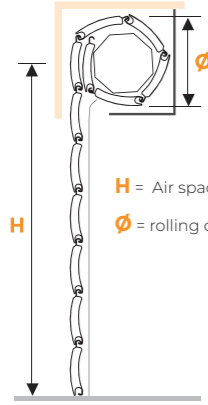

H = Air space measurement  
Ø = rolling diameter

### Compatible guides, terminals and accessories

Extruded aluminium guide <b>A16</b> 16 x 28 mm	Extruded aluminium guide <b>A27</b> 25,5 x 30 mm	Extruded aluminium guide <b>A28</b> 17 x 28 mm	Extruded aluminium guide <b>A30</b> 19,5 x 30 mm	Extruded aluminium guide <b>A53</b> 22 x 53 mm
Extruded aluminium guide <b>A75</b> 27 x 75 mm	Extruded aluminium guide <b>A80</b> 28 x 80 mm	Aluminium terminals 14 x 55 mm	Chains for slat L 150 mm	Safety intermediate chain for slat L 150 mm

### Colors

<b>Ral</b>									
	1 Bianco	36 Grigio 35	3 Grigio	2 Argento*	44 Ral 9007	42 Grigio 7016	19 Panna 1013	8 Avorio	4 Beige
<b>Wood</b>									
	5 Verde	21 Marrone cioccolato	7 Testa di moro	6 Rosso Mat-tone	53 Ral 3004	26 Ocra*	25 Terracotta	32 Sabbia	
<b>Raffaello</b>									
	24 Grigio Raffaello	22 Verde Raffaello							

The best possible representation of colors has been reported in our collection. Differences between these colors and the colors of the samples are not disputed. Some Ral\* and Raffaello colours fall within the price range of the particular colours.



## airlux combined

PVC AND ALUMINIUM THERMAL INSULATION ROLLER SHUTTERS WITH HIGH DENSITY POLYURETHANE WITH A LARGE BUTTONHOLE

Aluminium roller shutter with polyurethane foam interposition combined with self-extinguishing PVC. The particular coupling system between the two sides of the slat interrupts the thermal conductivity of the metal, making a cut of the thermal transmittance between the external and internal environment. The large buttonhole allows, when the roller shutter is lowered, a significant aeration and lighting of the environment.

<b>Profile size</b>	13 x 50 mm
<b>Weight per sqm</b>	High density approx. 6,6 kg
<b>Aluminium thickness</b>	Approx. 0,36 mm

### Standard inner PVC or foamed



### Rolling diameter

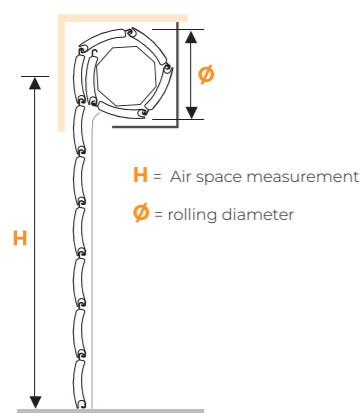

Roller Ø 60 (mm)	
H	Ø
1000	150
1200	155
1300	160
1400	165
1500	170
1600	175
1700	180
1800	185
1900	190
2000	195
2200	200
2400	205
2600	210
2800	220
3000	230
3300	240

### Profile

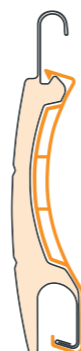

## Compatible guides, terminals and accessories

Extruded aluminium guide <b>A16</b> 16 x 28 mm	Extruded aluminium guide <b>A27</b> 25,5 x 30 mm	Extruded aluminium guide <b>A28</b> 17 x 28 mm	Extruded aluminium guide <b>A30</b> 19,5 x 30 mm	Extruded aluminium guide <b>A53</b> 22 x 53 mm
Extruded aluminium guide <b>A75</b> 27 x 75 mm	Extruded aluminium guide <b>A80</b> 28 x 80 mm	Aluminium terminals 14 x 55 mm	Chains for slat L 150 mm	Safety intermediate chain for slat L 150 mm

## Colori

EXTERIOR ALUMINIUM	Ral	1 Bianco	36 Grigio 35	3 Grigio	2 Argento	44 Ral 9007	42 Grigio 7016	19 Panna 1013	8 Avorio	4 Beige
		5 Verde	13 Verde 56	21 Marrone cioccolato	7 Testa di moro	6 Rosso Mat-tone	16 Rosso	26 Ocra	25 Terracotta	15 Azzurro (blu)
	Wood	10 Legno chiaro	50 Renolit miele	37 Legno castagno	11 Legno scuro	39 Legno noce				
	Raffaello								24 Grigio Raffaello	23 Marrone Raffaello
INNER PVC	Standard	1 Bianco	24 Avorio 1013	14 Avorio 217	15 Bruno 11	19 Grigio 35	3 Grigio 06	5 Verde 110	31 Verde 6005	29 Marrone 25
		76 Marrone 8017	20 Testa di moro	11 Rosso Mat-tone	CA2 Rosso Porpora	2 Legno chiaro	34 Legno 09	33 Legno F412	6 Legno scuro	50 Grigio 562
	Foamed	8 Bleu								
		Cristal White Ash	White 9152	Cream white 1379	Light grey 7251	Grigio 7016	Marrone cioccolato	Verde scuro 6125	Noce V	Golden Oak
		Sherwood								

The best possible representation of colors has been reported in our collection. Differences between these colors and the colors of the samples are not disputed. Some Ral\* and Raffaello colours fall within the price range of the particular colours.



## orienta 2.0

EXTRUDED ALUMINIUM ROLLER SHUTTER WITH ADJUSTABLE SLATS

Orienta 2.0 is the roller shutter system with adjustable slats, a perfect combination of roller shutter and shutter. Often using the roller shutter you are faced with choices of the type: lift the roller shutter to ventilate or lower it to shelter from sunlight and intrusions. In a single solution Orienta 2.0 allows you to ventilate, illuminate and protect from the sun, in complete safety. Its operation does not require mechanisms inside the rails, so you can install it as a normal roller shutter on new buildings or replace the existing ones.

For widths greater than 1.5 m intermediate support will be inserted. Check that the internal width of the rail is minimum 19 mm. The product is only available in version motorized.

**Weight per sqm** c.ca 9,2 Kg

Inner rolling		Exterior rolling	
H	Ø	H	Ø
1600	195	1600	205
1800	200	1800	210
2000	215	2000	220
2200	225	2200	230
2400	227	2400	235
2500	238	2500	240
2800	248	2800	250
3000	253	3000	260

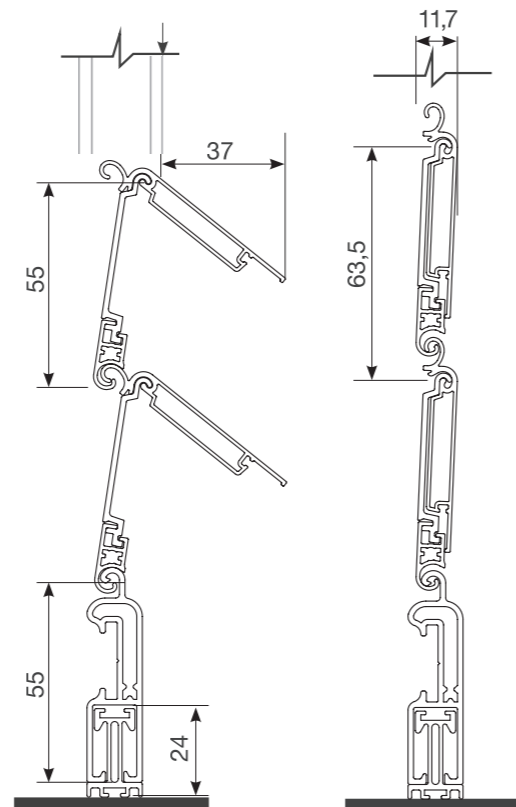

### Compatible guides, terminals and accessories

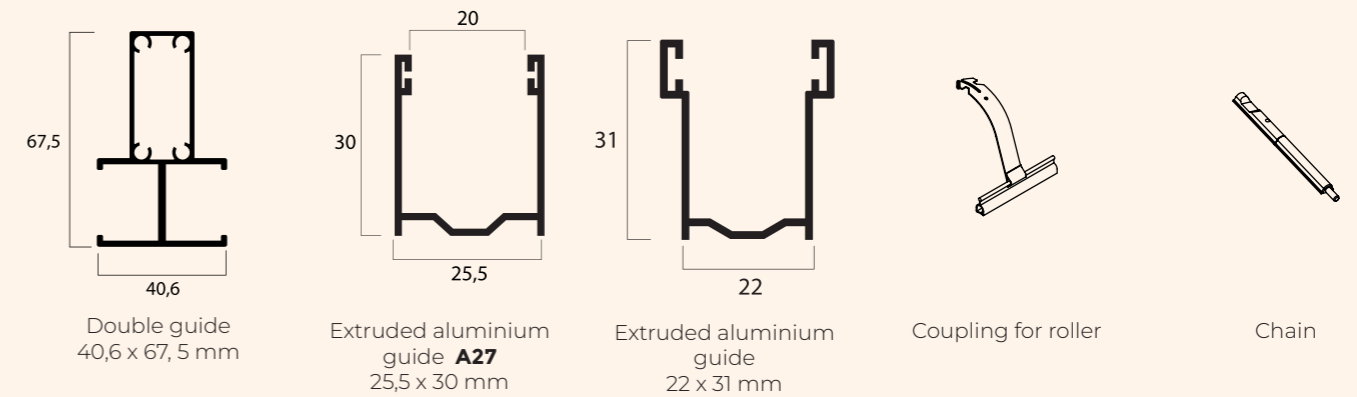

Double guide  
40,6 x 67,5 mm

Extruded aluminium  
guide **A27**  
25,5 x 30 mm

Extruded aluminium  
guide  
22 x 31 mm

Coupling for roller

Chain

### Colors

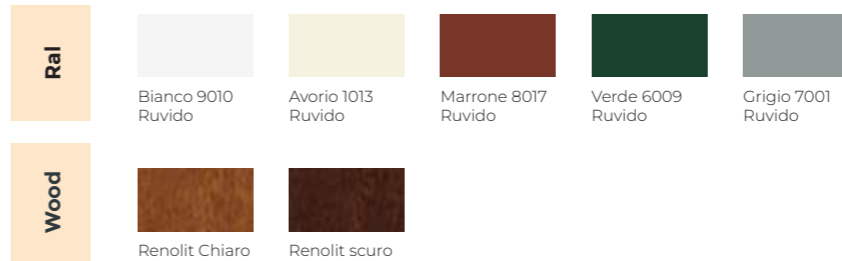

### Colors of the accessories



The best possible representation of colors has been reported in our collection. Differences between these colors and the colors of the samples are not disputed.

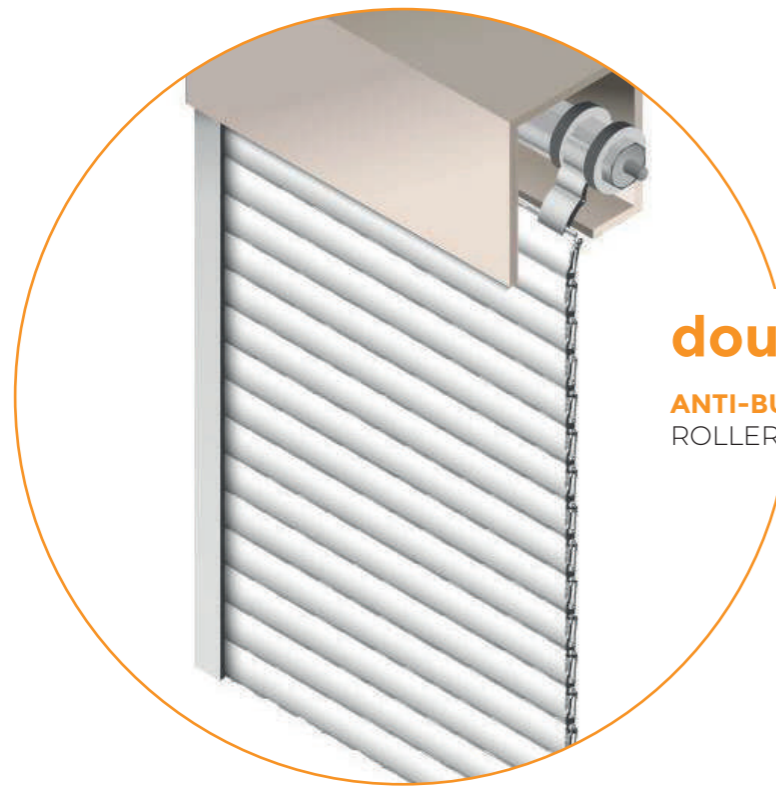

## double safe

**ANTI-BURGLARY** EXTRUDED ALUMINIUM ROLLER SHUTTER AND EXTERIOR BLIND

Double Safe is a safety reinforced extruded aluminium roller shutter and exterior blind. Automatic mechanical locking thanks to internal perimeter locking blocks ensure anti-burglary.

The configuration of the distances between the slats during operation allows you to easily manage the privacy and the variation of daily light to adapt to every moment of the day. The modern design, functional and discreet suitable for any architectural style.

The motor drive allows you to operate the roller shutter with a simple gesture and allows you to adjust the light and shade in your home.

<b>Profile size</b>	12,4 x 72,4 mm
<b>Weight per sqm</b>	13 Kg
<b>Maximum size</b>	2500 x 2500 mm



**Anti-burglary class RC3**

Rolling diameter	Roller $\phi$ 70 (mm)		Profile
	H	$\phi$	
	800	200	
	900	220	
	1000	220	
	1100	220	
	1200	230	
	1300	230	
	1400	230	
	1500	240	
	1600	240	
	1700	240	
	1800	250	
	1900	250	
	2000	260	
	2100	260	
	2200	260	
	2300	270	
	2400	270	
	2500	270	

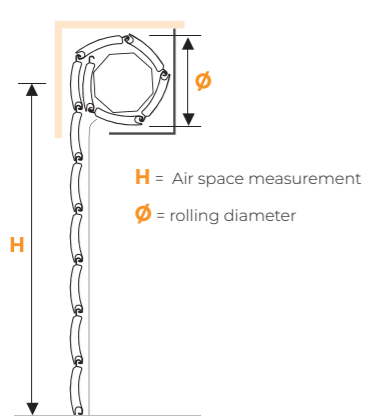

### Compatible guides, terminals and accessories

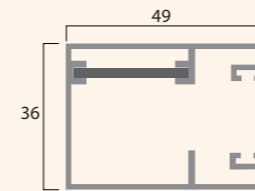

Guide to be recessed with brush

**Rolling shutter width**  
**Internal guide measurement**  
 + 80 mm

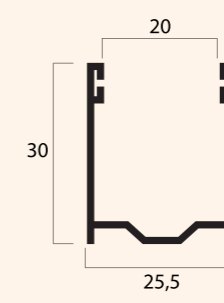

Extruded aluminium guide **A27**  
 25,5 x 30 mm

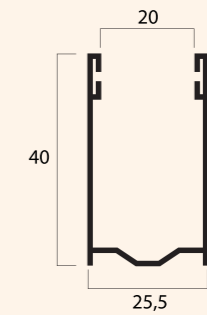

Extruded aluminium guide **A40**  
 25,5 x 40 mm

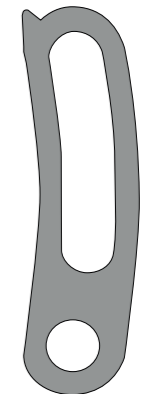
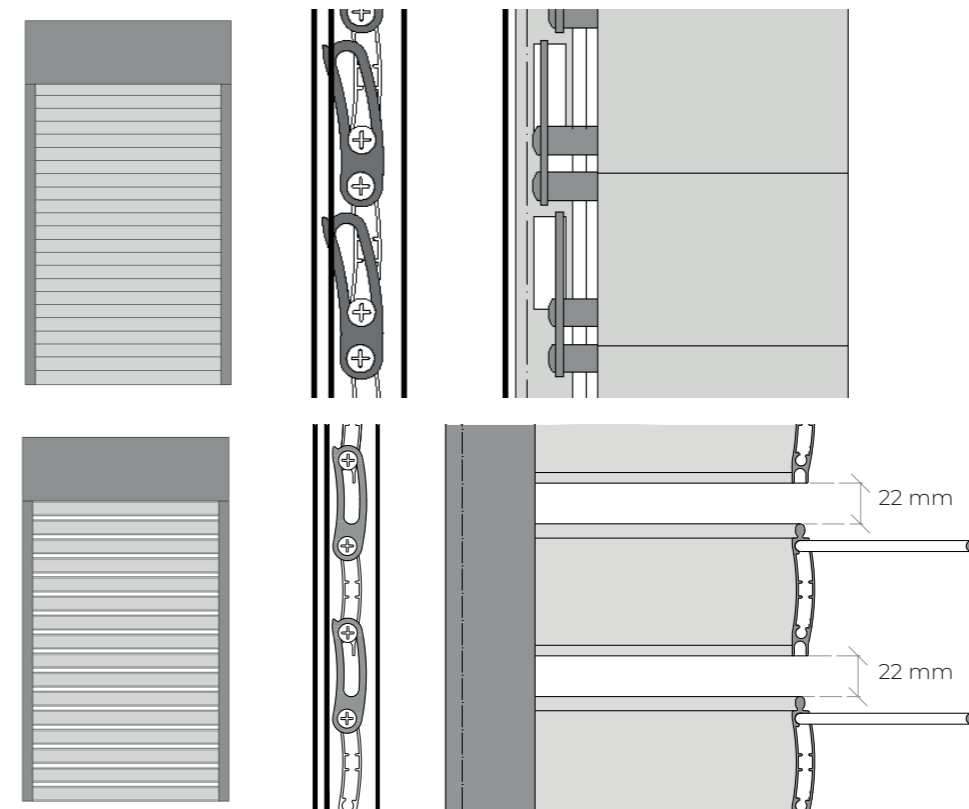

**Self-locking connecting rods**  
 30 pieces per linear meter. They are activated simultaneously ensuring an unprecedented lifting seal.

### Colors



The best possible representation of colors has been reported in our collection. Differences between these colors and the colors of the samples are not disputed.





## visionplus

EXTRUDED ALUMINIUM ROLLER SHUTTER

Visionplus is the roller shutter that offers maximum visibility from the inside, allows the ventilation of the house and allows greater energy savings as it reduces the solar radiation to the inside.

Available for internal and external wrapping.

<b>Profile size</b>	8,5 x 10 mm
<b>Weight per sqm</b>	11,8 / 11,9 kg

Ø rolling	Inner rolling				Exterior rolling				Profile
	Roller Ø 40 (mm)		Roller Ø 60 (mm)		Roller Ø 40 (mm)		Roller Ø 60 (mm)		
H	Ø	H	Ø	H	Ø	H	Ø		
1000	150	1000	155	1000	150	1000	155	 Inner rolling   Exterior rolling	
1200	160	1200	170	1200	160	1200	165		
1400	170	1400	175	1400	175	1400	175		
1600	175	1600	190	1600	180	1600	185		
1800	190	1800	195	1800	190	1800	195		
2000	195	2000	205	2000	200	2000	200		
2200	205	2200	210	2200	210	2200	220		
2400	210	2400	220	2400	220	2400	220		
2600	220	2600	225	2600	225	2600	230		
2800	225	2800	235	2800	235	2800	240		
3000	235	3000	240	3000	240	3000	245		
3200	240	3200	250	3200	245	3200	250		
3400	250	3400	255	3400	255	3400	255		
3600	260	3600	255	3600	260	3600	265		
3800	260	3800	265	3800	265	3800	270		
4000	270	4000	275	4000	275	4000	275		
4200	275	4200	280	4200	275	4200	285		
4400	280	4400	285	4400	285	4400	285		
4600	285	4600	290	4600	290	4600	295		

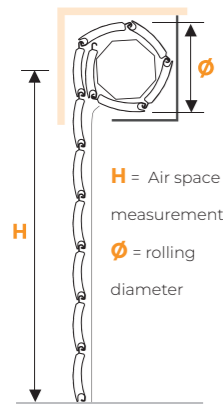

### Compatible guides, terminals and accessories

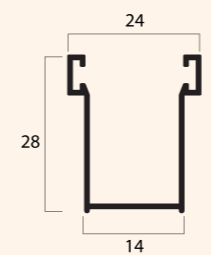

Extruded aluminium guide **A14**  
14 x 28 mm

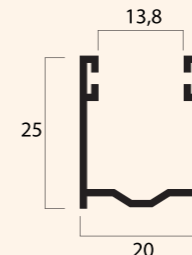

Extruded aluminium guide **A25**  
20 x 25 mm

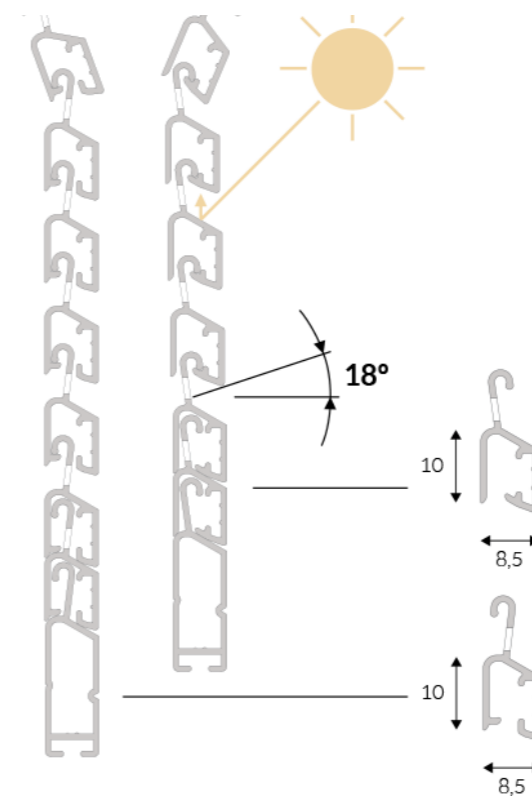

When the angle of the sun exceeds 18°, Visionplus does not allow direct passage inwards.

Greater energy savings by reducing solar radiation to the interior.

Colors								
Bianco	Argento	Ral 7016	Ral 7022	Ral 8014	Nero opaco	Ral 7016 opaco	Ral 7016 opaco	Ral 7022 opaco
Ral 8014 opaco	Golden Oak	Ral 7030						

The best possible representation of colors has been reported in our collection. Differences between these colors and the colors of the samples are not disputed.

## aluminium external boxes

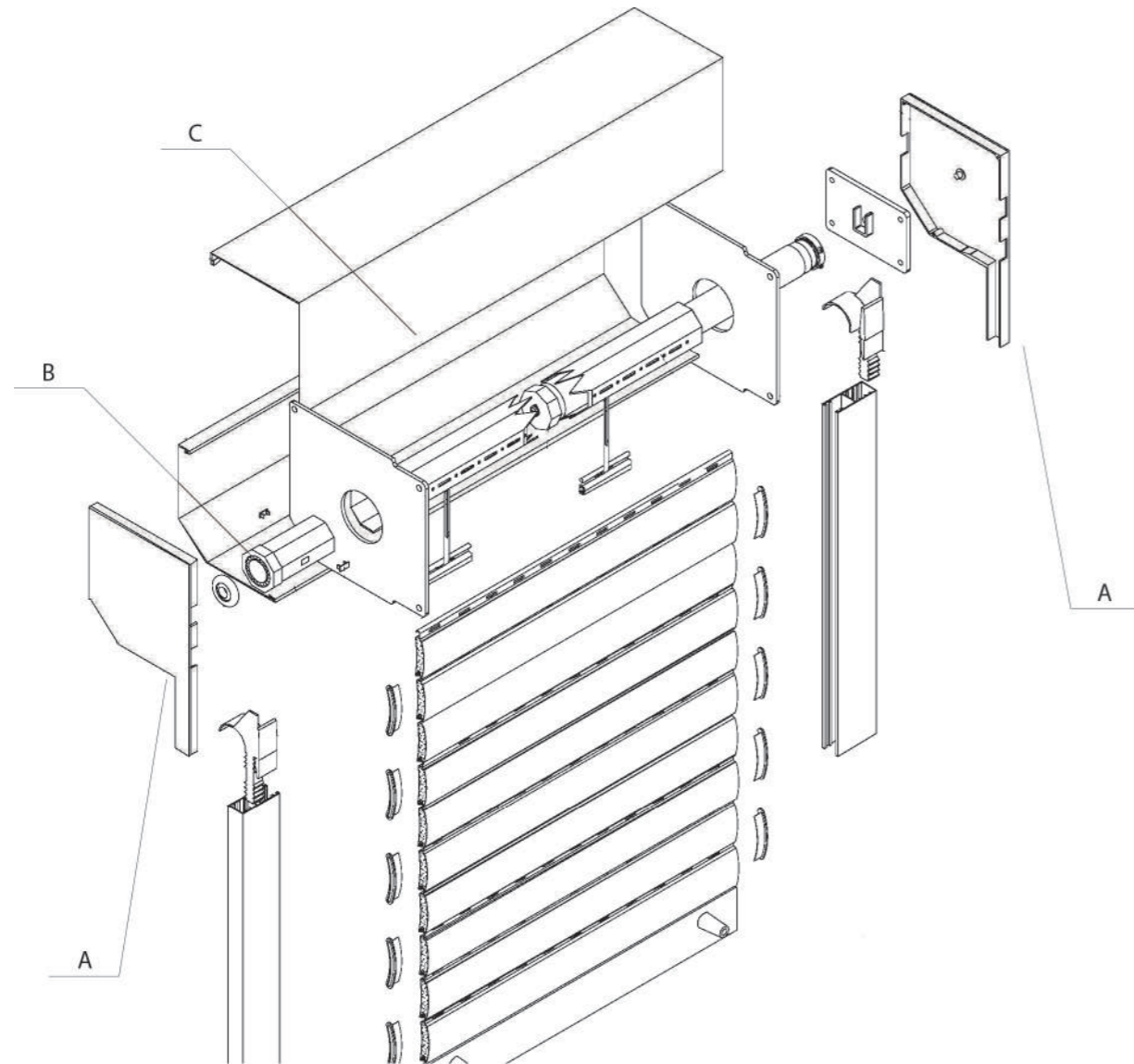

### Type of installation aluminium external box

#### INSTALLATION WITHIN THE DOORWAY

Inner rolling direction

External rolling direction

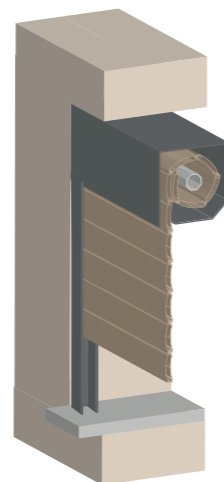
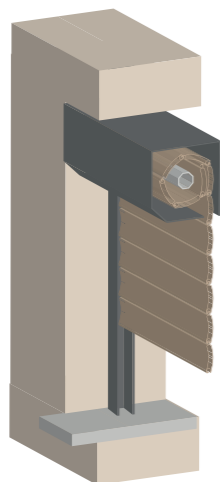

#### ON THE FAÇADE

Inner rolling direction

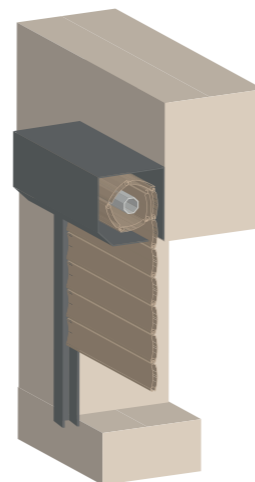

## thermal insulating boxes STRUCTURE AND COMPONENTS

The thermal insulating box is an innovative system that allows to transform a raw hole in a finished hole without thermal and acoustic bridges and ready to accommodate any window.

#### Ease of use

Quick and easy installation without interruption of construction work.

#### Design flexibility

It meets every need thanks to a rich range of models.

#### High stability

High density of polystyrene and armor with galvanized iron cage.

#### Thermal and acoustic insulation

Excellent performance in terms of acoustic insulation. Thermal and acoustic bridges are eliminated by improving insulation by at least 50% compared to traditional systems.

The boxes are made of self-extinguishing closed cell expanded polystyrene (EPS) and have a thickness of 6 mm.

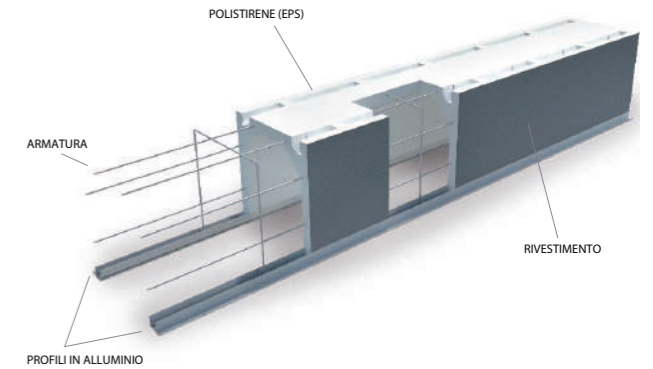

It is possible to request the presence in the structure of an electro-welded armature in galvanized steel 4 mm with 250 mm pitch and two lower profili in aluminum. These three elements are incorporated by the expansion of polystyrene creating a solid, stable and at the same time light structure. The upper part of the box is shaped with dovetail recesses to facilitate the coupling of the concrete lintel. The side facades are covered with cement mortar to facilitate the subsequent application of plaster or other finitura.

#### Header panel

This solution is adopted when the frame is in briquette (center wall). It consists of a panel that slides on two side rails, fixed in the lower wall of the box. The ceiling is sealed on a stop profile placed on the window.

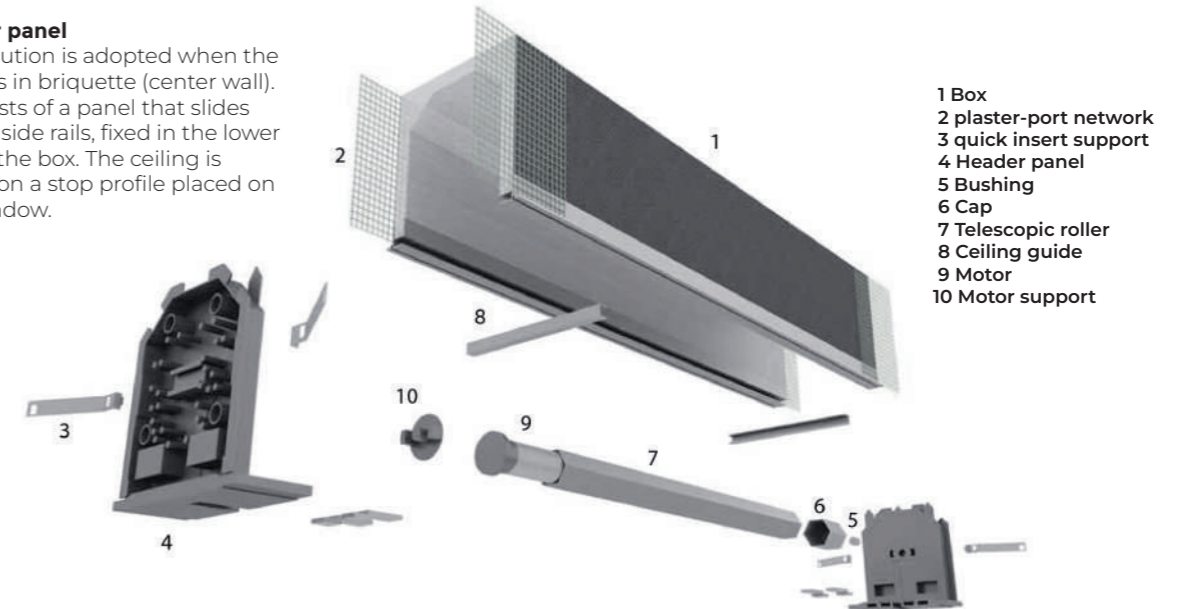

#### How is it provided?

The box is supplied complete with:

- header panel
- supports for galvanised bearings
- anchoring supports
- PVC ceiling guides with draught excluder seal

It can be supplied, on request, complete with closing cover in chipboard or MDF melamine in various finishes. You can also request all the necessary items for the maneuver with belt.

#### The advantages of expanded polystyrene

The EPS has a closed cellular structure formed by 98% air that allows the box to ensure thermal insulation and create a barrier against moisture. Being an inert material it is not attachable to fungi, bacteria and small animals and is able to maintain this characteristic unchanged over time. In addition to contributing to the reduction of fuel consumption for heating is 100% recyclable. The box is environmentally friendly and limits the emission of CO<sub>2</sub> in the environment, thanks to better insulation of the building.

# Type of boxes

## plus

Thermal insulating boxes can be installed on any type of construction in different sizes and prepared to accommodate any model of roller shutter and operating system.

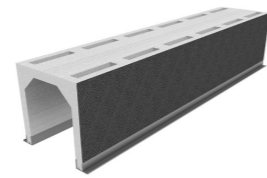
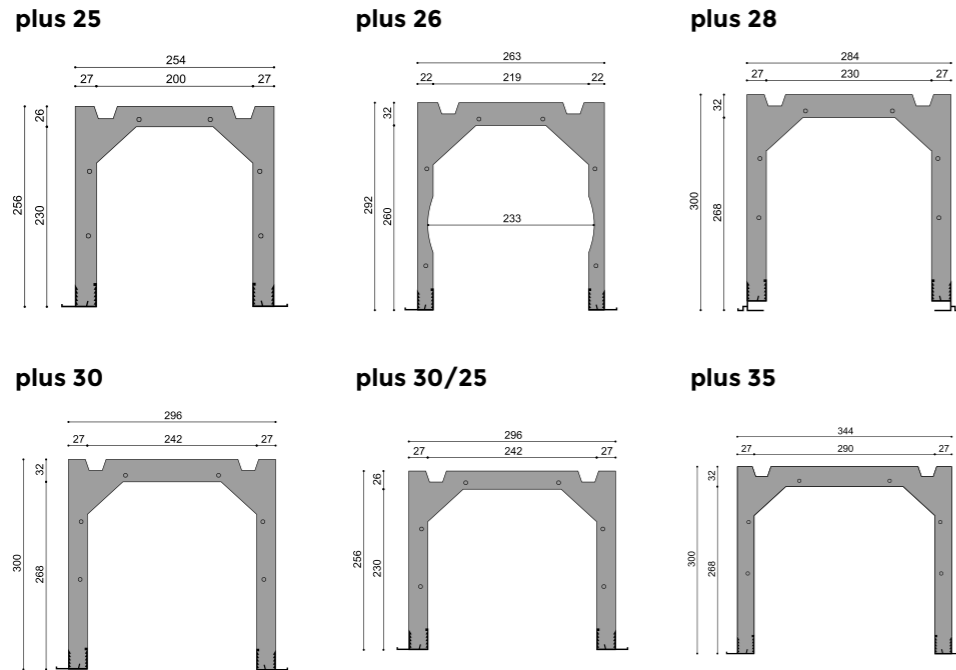

## meta

Suitable solution in the presence of external coating, made with polystyrene profile with shaped sheet to measure. Suitable for renovations. Also with front inspection.

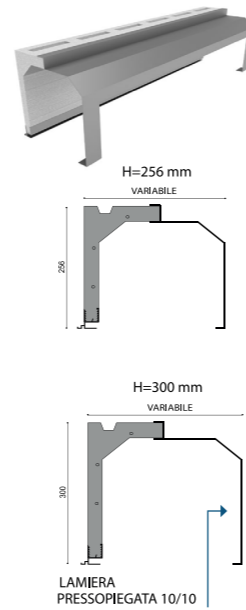

# Thermal insulating monobloc system

- SOUND INSULATION**
- HEAT-INSULATING**
- IMPROVING ENERGY EFFICIENCY**
- BOX, SUBFRAME AND INSULATION IN A SINGLE ELEMENT**
- SUPPLIED ON SITE ALREADY ASSEMBLED**

Adaptable thermo-insulating monobloc to any type of construction, thanks to the wide range available and to the multiple possibility of customization. **It is supplied complete and assembled.**

It is composed of insulating shoulders in extruded polystyrene with a fibro-cement finish and an overlying box in expanded polystyrene. The system is made to measure and designed to turn a raw hole into a finished hole and ready to accommodate any type of window and roller shutter.

The performance and quality of the materials and the high technology make the product unalterable over time. Compared to traditional bins, box, frame and insulation are included in a single element supplied on site already assembled. These components that can be among the most critical in the window hole, combined together provide numerous advantages that can be summarized in simplicity and performance that equate to convenience and comfort of living.

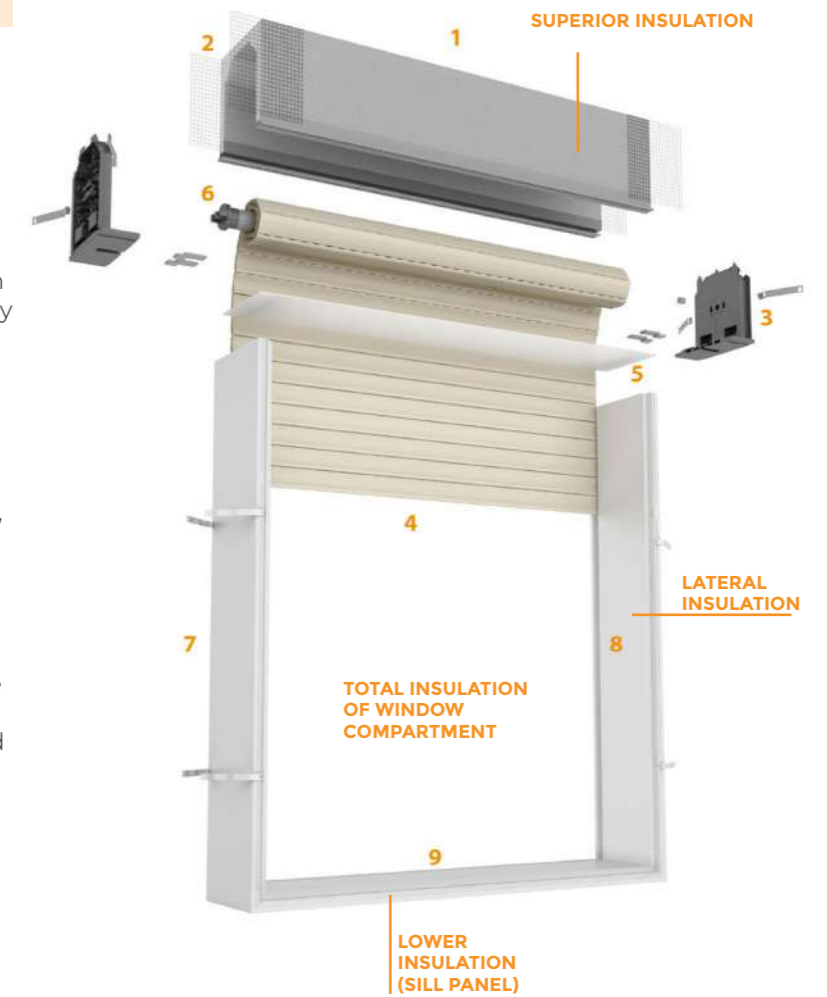

- 1 Boxer
- 2 Plaster-port network
- 3 Header panel
- 4 Roller shutter
- 5 Closing ceiling
- 6 Motor
- 7 Side shoulders
- 8 Roller shutter guide
- 9 Sill panel

### Sistema con telaio zincato

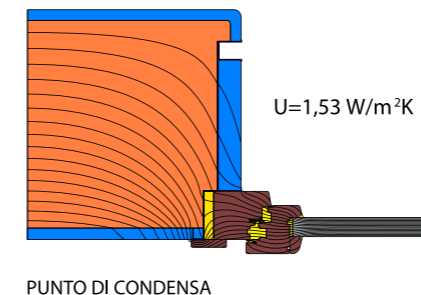

### Sistema con monoblocco termoisolante

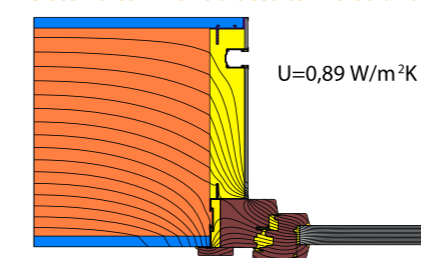

Comparing this system with a standard pre-frame solution in galvanized sheet it is evident the elimination of thermal bridges, greatly improving the thermal efficiency of the window compartment as it allows to create a clear division between inside and outside, together with the frame, eliminating elements that can connect the inside and the outside, as in traditional frames.

## sole

Structured box to accommodate any type of sunshades, can be integrated with additional panels to adapt to the sunshade system provided.

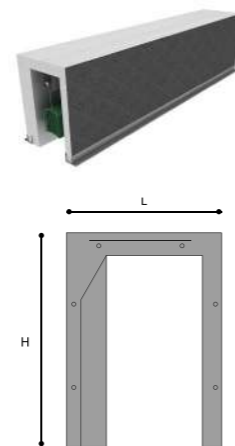

	L	H
SOLE 22/30	219	300
SOLE 22/35	219	350
SOLE 22/40	219	400

## modu

Solution that allows to adapt the shape of the box to the different types of masonry with a special variable covering profile (thickness 50-60 cm).

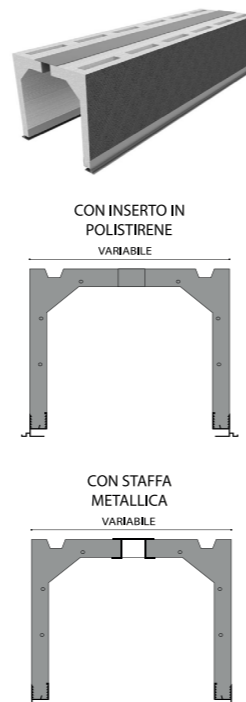

Solution that allows you to adapt the shape of the box to the different types of masonry with a special variable coating profile (thickness 50-60 cm). The oversized shoulder can also be placed outside for special uses.

## Iper

Recommended for masonry 30 cm, box with enlarged inner shoulder 40 mm to increase the thermal insulation and acoustic.

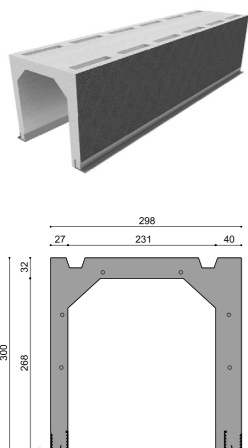

## Iper M

Recommended for masonry 35 cm, box with enlarged inner shoulder 74 mm to increase the thermal insulation and acoustic.

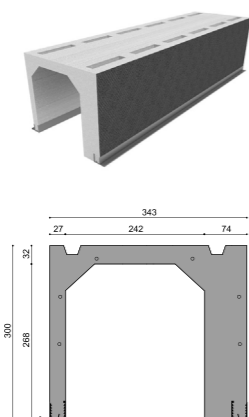



# exterior blinds

Exterior blinds help to create an optimal environment from the point of view of brightness and heat. They are essential for the energy saving of the building.

In addition to safety and shielding functions, exterior blinds are also an architectural and aesthetic element in building facades.

**HIGH PROTECTION AGAINST SOLAR RADIATION**

**EFFECTIVE PROTECTION OF PRIVACY**

**REDUCTION OF HEAT IN THE INTERNAL ENVIRONMENT**

**REDUCTION OF EXTERNAL NOISE LEVEL**

**ARCHITECTURAL ELEMENT OF DESIGN FACADE**



## Types of lamellas available

### C 50 / 65 / 80 / 60 FLEXYdisp

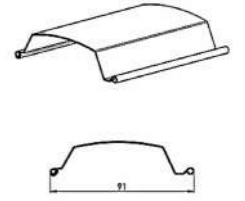
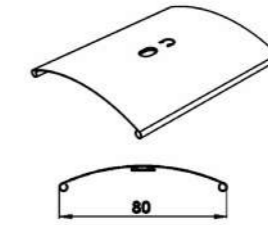
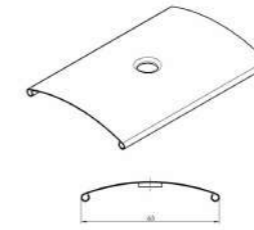
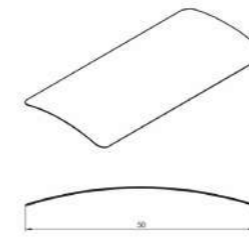
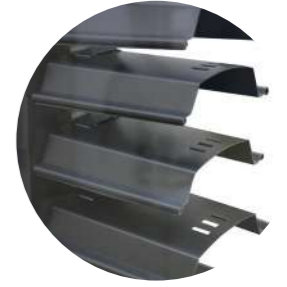
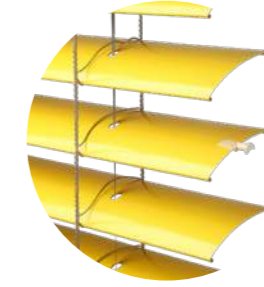

### T 90

### S 65 / 90

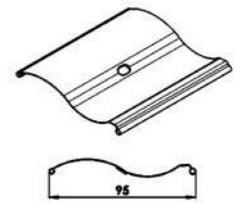
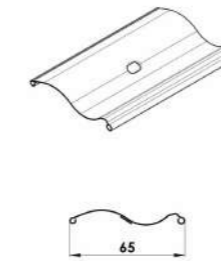

### Z 70 / 90 dis

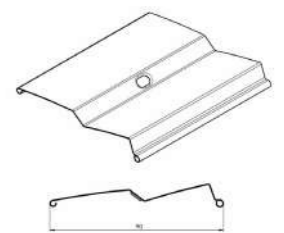
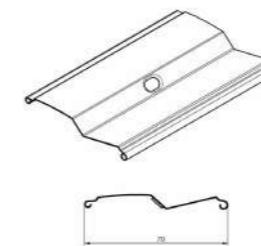
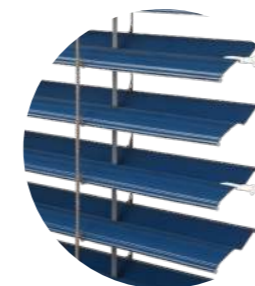



+ SMART  
+ GREEN

EffeZeta System ha deciso di ridurre l'uso della carta dove possibile. Siamo certi che sarai felice, insieme a noi, di contribuire con questo piccolo gesto alla tutela dell'ambiente.

Download the full version of our catalogues by scanning the QR code or by visiting the Download page of our website

[www.ffezetasystem.com](http://www.ffezetasystem.com)

### What will you find?



Complete data sheets of products  
Colours and options available  
Accessories for heavy duty  
Roller shutter guides  
Shutter motors  
Manoeuvring systems  
Boxes and monoblocs  
Complete exterior blinds catalogue

## GENERAL TERMS AND CONDITIONS OF SALE

### 1. Premises and Scope

1.1 These General Terms and Conditions of Sale (GTCS) apply to all purchase orders of mosquito screens and/or other custom-made items and/or products marketed according to the instructions provided by the Customer, sent in compliance with what is specified in point 3. below, and form an integral and substantial part of the contracts entered into between the Customer and EFFEZETA SYSTEM SRL.

1.2 In the event of a conflict between these General Terms and Conditions and the terms and conditions agreed in writing for the individual sale and set out in the confirmation email sent by EFFEZETA SYSTEMS SRL, the latter shall prevail.

1.3 For the purpose of these General Terms and Conditions, the term "Customer" shall mean the person, identified by the data entered upon acceptance of these General Terms and Conditions, who requests, orders and purchases the product subject matter of the contract.

1.4 For any clarifications regarding these GTCS, the characteristics of the products, specific conditions and anything else, the Customer is invited to contact EFFEZETA SYSTEM SRL directly as detailed below.

1.5 The version of these GTCS currently in force is always available at [www.ffezetasystem.com](http://www.ffezetasystem.com).

### 2. Prices and terms of payment

2.1 The Prices of the Products are those in the price list valid at the time of delivery and are exclusive of VAT, and shipped ex works. Taxes, duties, shipping, insurance, installation, end-user training, after-sales service, etc. are not included in the prices, unless expressly quoted separately.

2.2 Payment shall be made on the terms and in the manner set out in the invoice. Direct remittances must be made by bank transfer, bank draft or cash. The goods remain the exclusive property of the Company until full and final payment has been made. Payment may not be suspended or delayed for any reason whatsoever. In the event that the Buyer fails to pay according to the terms and in the manner stated on the invoice, in addition to the bank charges, the outstanding handling fee of EUR 15.00 and interest on arrears shall be charged, in addition to the applicable interest rate in force. During the transaction period from non-payment to invoice settlement, the Company shall suspend and/or cancel any orders and/or deliveries in progress and block the Buyer from placing new orders. Once the balance has been paid and following the above, the Company may, at its own discretion, request advances on payments or a security deposit. If the Buyer's business is taken place in a manner that is not in compliance with the ordinary course of business, by which is meant, without limitation, the issuance of seizure orders or liens, or when insolvency proceedings have occurred or are pending, the Company shall have the right to request any pending payment immediately due and payable. The purchaser has no right to set-off, retain or reduce the amounts due unless its claim to do so has been permanently upheld in court.

### 3. Orders and quotes

3.1 Orders must be placed in writing, by fax or e-mail, using the order form available in the Download section of our website. For telephone orders, the Company is not liable for any errors. Orders must detail the order number, an exact list of the goods ordered with possible reference to their product code, their quantity, measurements, unit and total price, destination address and any further instructions for delivery. In the case of measurements received without specification as to whether they are completed measurements or span measurements, the Company will automatically consider them as completed measurements, unless otherwise specified in the price list. The information detailed in our catalogues or advertising brochures, such as technical characteristics of products or components, dimensions, assembly diagrams, colours, etc., is purely indicative, due to the technical specifications and technological evolution of the company's products. Binding data may be provided from time to time and upon specific request of the same. In order to improve the quality of the product, the Company reserves the right to modify it without prior notice and even after acceptance of the order.

3.2 If the order is preceded by a quote by the Seller, the quote shall be valid for a maximum duration of 30 days, unless otherwise stated. The contract of sale shall in any case be deemed entered into upon confirmation of the order by the Seller. The Purchaser must check that the master data is correct and, if there is an error, report it promptly. Otherwise, the Seller shall not be jointly and severally liable as provided in Art. 41 Presidential Decree 26/10/72, No. 633.

3.3 The Company reserves the right to accept order modifications or cancellations depending on the progress of the order. Any changes must be notified promptly within the day of the order and no later than 24 hours after the order is placed. If no notification is received within 24 hours, the order will be considered confirmed and processed. Therefore, the company will not be able to accept claims regarding products that do not comply with the requirements and will be held harmless of any liability. In any case, changes to or cancellation of the order not notified in writing shall not be accepted.

### 4. Methods of delivery/shipping

4.1 The Company shall deliver the products to its customers, using a carrier it trusts, or directly if the place of delivery falls within the areas covered by the Company's delivery service.

4.2 EFFEZETA SYSTEM shall not be liable for non-delivery or delayed delivery if this is due to force majeure such as - purely by way of example - strikes, public authority measures, rationing or shortages of energy or raw materials, transport difficulties, fires or floods.

4.3 In the cases provided for in the preceding paragraph, the customer shall not be entitled to any compensation, indemnity or discount for any reason whatsoever.

### 5. Acceptance and/or return of products

5.1 All products shall be deemed accepted at the time of delivery, subject to the purchaser's right to report defects or non-conformities in the product. This shall be reported IN WRITING and with specific reasons included or the claim shall be void. If delivery is by carrier, check the quantity and packaging of the products and note any differences in the transport document, accepting with reservation. The so-called 'ad nutum' withdrawal is forbidden. Upon prompt notification of the defect or non-conformity, the Company shall, in consultation with the customer, replace the defective products or refund the price. The disputed goods shall be delivered to the Company no later than 7 days from the date of receipt of the claim report for the necessary verifications. The Company is entitled to test the products upon their return and to charge the customer for any costs incurred in the event of an unfounded claim.

### 6. Warranty

6.1 The seller warrants that the products are free from defects and in compliance with the technical manufacturing specifications. The warranty is for free replacement and/or repair of parts with manufacturing defects. Not covered by the warranty: replacement of drapes worn out by the weather or damaged by third parties. The warranty is excluded for: damage during transport, poor storage, tampering, faulty assembly, inexperience of use, exceeding the performance limits, as well as for all other causes that are not the direct fault of the Seller and if the consequences result from incorrect or incomplete information provided in the order. The warranty is voided automatically when, without the seller's authorisation, replacements, repairs or modifications of any kind are made. In such a case, the Seller shall be held harmless from any civil and criminal liability, and the warranty shall be voided. The statutory warranty periods are peremptory and apply even if the material is not used. Material that is deemed to be defective shall be sent, with prior notice to the Company, carriage paid. The Company shall issue a return authorisation and the replaced material shall remain the property of the Company.

### 7. Compensation for damages

7.1 For production errors of the goods, defects of the same, as well as their malfunctioning in relation to the agreed purpose of use, for which, in any case, the liability of the Company shall be ascertained, the reproduction and return of the same goods identical in quantity and quality (kind and type), free of any defects and fully functional, shall be recognised exclusively. Therefore, all other costs incurred, such as, for example, dismantling, reassembly, man-hours, travel time, transport charges, etc., as well as any other direct or indirect compensation are excluded.

### 8. Intellectual and Industrial Property

8.1 The Company reserves all rights to all content (texts, images, etc.) appearing in its printed material and on the website. Such content may only be used by third parties with prior written consent. The customer acknowledges the validity of any exclusive rights arising from the Company's intellectual and industrial property rights. For any disputes that may arise the jurisdiction is hereby waived in favour of the Court of Santa Maria Capua Vetere.

## EffeZeta System

### CASERTA

Località Stradisi  
81017 - S. Angelo d'Alife, CE  
+ 39 0823 228358  
+ 39 366 7418951  
Fax 0823 914258

### ROMA

Via di Cervara, 129  
00155 Roma RM

### MILANO

Via Giuseppe di Vittorio, 7  
20060 - Liscate, MI

### DUBAI

48 Burj Gate,  
10th Floor, room 1001  
Downtown - Dubai - EAU  
tel: +971 4 3216260

### Info

[info@ffezetasystem.com](mailto:info@ffezetasystem.com)

[www.ffezetasystem.com](http://www.ffezetasystem.com)



### Stampa Luglio 2022

The technical diagrams of this catalogue are indicative. The company reserves the right to make changes at any time and without notice, it is not liable for damage due to improper use or laying out of the rule.

The best possible representation of colors has been reported in our chart, the colors reproduced could be subject to variations due to production batches and typographical fidelity.



[www.effezetasystem.com](http://www.effezetasystem.com)

