

Sistema Atlantis



www.daliform.com



Disposable formwork for
ventilated under-floor cavities



daliform
GROUP
Building Innovation © Creatori dell'Iglù®

KEY:



Water, collection tanks



Air, moisture



Radon



Cold rooms



Utility passage



Foundations



Certifications



Ecocompatibility



SWITCHBOARD

Telephone +39 0422 2083



FOREIGN COMMERCIAL SECRETARY OFFICE

export@daliform.com



TECHNICAL SECRETARY OFFICE

tecnico@daliform.com



variable height from 56 cm to 300 cm



Sistema Atlantis

Sistema Atlantis (Atlantis System) is an advanced system for creating cavities in general, under-floor cavities and ventilated floors in newly constructed or restructured civil and industrial buildings, accumulation tanks, dispersion tanks, honeycomb rafts, low temperature cold rooms.

The Atlantis System is used when the depth of the under-floor cavity or cavity is such that the classic Iglu® formworks cannot be used, with the advantage that the constant diameter of the elevator pipes makes it possible to minimise the use of concrete for filling. The main system features are speed, simplicity and cost performance.

Furthermore, with Atlantis, a sanitary space is obtained with a suitable humidity barrier and, if properly ventilated through piping connected outdoors, it is a tool for the disposal of the Radon gas present in the ground.



Advantages

- Ease of positioning as it is light-weight and simple to install through the linking of the elements, with time savings up to 80%.
- Minimum use of concrete for level filling thanks to the lowered dome form, which permits maximum resistance with minimum slab thickness.
- The possibility, due to the pipe system, to have any height up to 3 m supplied to the yard.
- Possibility to bear loads of considerable size by providing the vertical supports with suitable reinforcement.
- Adaptable to non-standard spaces as the modules can be cut without underpinning.
- Passage of systems under the pavement in all directions: perpendicular and diagonally.
- If used in combination with the disposable Muro formwork system it is possible to create elevation plates, both perimetric as well as intermediate, together with the upper slab preventing formwork dismantling, with considerable time savings.
- Total ventilation of the space and air flows in all directions.
- Simple material management in the yard, as it is not bulky and can be exposed to bad weather.

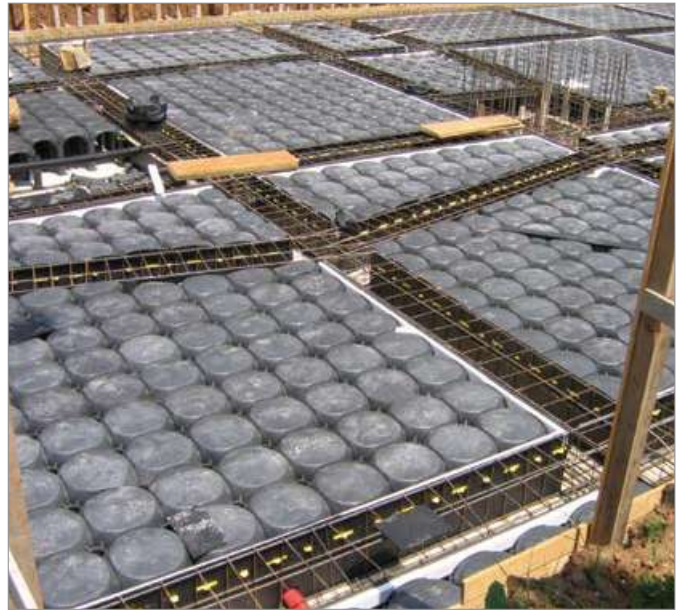

Atlantis System in combination with Muro formwork



Adjustment to different layouts thanks to the compensation accessories



Example of the passage of utilities



Perfect lateral occlusion thanks to the accessories



Easy to pose



Ramps



Compensate gaps of quotes

Applications

Atlantis is a system for creating under-floor cavities where there is considerable height available. It can be used for the distribution of systems and technological networks under the pavement so they do not need to be buried in screed.

It is suited for creating thermally insulated cavities for cold rooms with or without forced ventilation. It is the ideal solution for creating accumulation or dispersion tanks and for pool restructuring. Thanks to custom sized elevator pipes, it is the ideal system for creating inclined or multilevel surfaces.

Atlantis, when used in combination with the special Muro formwork, represents an innovative, quick and economic solution for the creation of honeycomb or box foundation rafts (superrafts), a reduced use of concrete and steel makes it possible to obtain extreme stiffness even if the ground does not provide much load bearing capacity.



Building for residential use



Interspace with root saving function



Rainwater accumulation tank

Atlantis System range

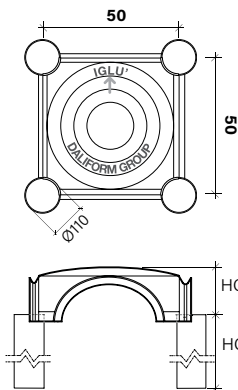

Sistema **Atlantis 50 x 50 cm**



	H cm ▶	from H 56 to H 80	from H 81 to H 110
Useful dimensions bxb*	cm	50 x 50	50 x 50
Dome height HC	cm	16	16
Dome weight	kg	1,680	1,680
Pipe height HG	cm	from 40 to 64	from 65 to 94
Concrete use pipe Ø 110 mm	m ³ /m ²	from 0,048 to 0,056	from 0,056 to 0,068
Pallet dimensions*	axbxh	110 x 110 x 250	110 x 110 x 250
	Weight kg	490	490
	Units	300	300
	m ²	75	75

*Referred to the dome only. / The product is not affected if weathered.

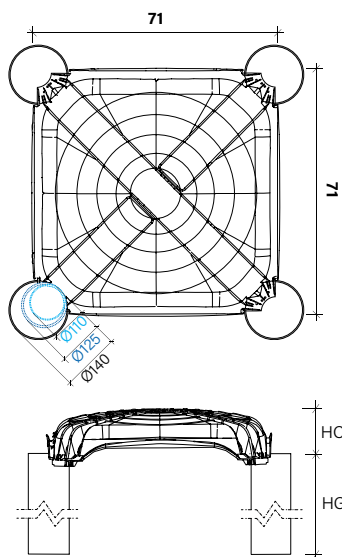

Sistema **Atlantis 71 x 71 cm**



	H cm ▶	from H 56 to H 80	from H 81 to H 110
Useful dimensions bxb*	cm	71 x 71	71 x 71
Dome height HC	cm	15	15
Dome weight	kg	3,093	3,093
Pipe height HG	cm	from 41 to 65	from 66 to 85
Concrete use pipe Ø 110 mm	m ³ /m ²	from 0,041 to 0,045	from 0,045 to 0,049
Concrete use pipe Ø 125 mm	m ³ /m ²	from 0,042 to 0,048	from 0,048 to 0,055
Concrete use pipe Ø 140 mm	m ³ /m ²	from 0,045 to 0,052	from 0,052 to 0,061
Pallet dimensions*	axbxh	79 x 149 x 259	79 x 149 x 259
	Weight kg	660	660
	Units	230	230
	m ²	115	115

*Referred to the dome only. / The product is not affected if weathered.

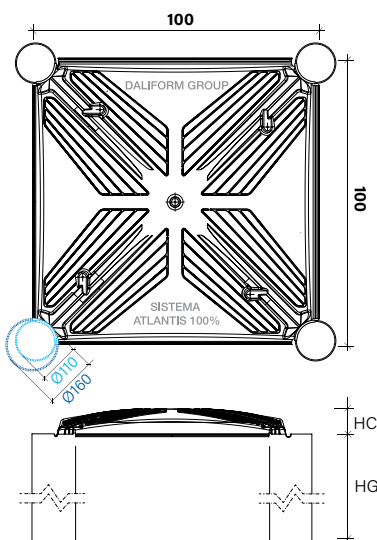

Sistema **Atlantis 100 x 100 cm**



	H cm ▶	from H 56 to H 80	from H 81 to H 110
Useful dimensions bxb*	cm	100 x 100	100 x 100
Dome height HC	cm	12	12
Dome weight	kg	10,164	10,164
Pipe height HG	cm	from 44 to 68	from 69 to 98
Concrete use pipe Ø 110 mm	m ³ /m ²	from 0,038 to 0,040	from 0,040 to 0,043
Concrete use pipe Ø 160 mm	m ³ /m ²	from 0,043 to 0,047	from 0,047 to 0,053
Pallet dimensions*	axbxh	110 x 110 x 254	110 x 110 x 254
	Weight kg	700	700
	Units	70	70
	m ²	70	70

*Referred to the dome only. / The product is not affected if weathered.



from H 111 to H 140	from H 141 to H 170	from H 171 to H 200	from H 201 to H 230	from H 231 to H 260	from H 261 to H 300
50 x 50	50 x 50	50 x 50	50 x 50	50 x 50	50 x 50
16	16	16	16	16	16
1,680	1,680	1,680	1,680	1,680	1,680
from 95 to 124	from 125 to 154	from 155 to 184	from 185 to 214	from 215 to 244	from 245 to 284
from 0,068 to 0,079	from 0,079 to 0,089	from 0,089 to 0,100	from 0,100 to 0,111	from 0,111 to 0,122	from 0,122 to 0,136
110 x 110 x 250	110 x 110 x 250	110 x 110 x 250	110 x 110 x 250	110 x 110 x 250	110 x 110 x 250
490	490	490	490	490	490
300	300	300	300	300	300
75	75	75	75	75	75



from H 111 to H 140	from H 141 to H 170	from H 171 to H 200	from H 201 to H 230	from H 231 to H 260	from H 261 to H 300
71 x 71	71 x 71	71 x 71	71 x 71	71 x 71	71 x 71
15	15	15	15	15	15
3,093	3,093	3,093	3,093	3,093	3,093
from 86 to 125	from 126 to 155	from 156 to 185	from 186 to 215	from 216 to 245	from 246 to 285
from 0,049 to 0,056	from 0,056 to 0,061	from 0,061 to 0,067	from 0,067 to 0,072	from 0,072 to 0,078	from 0,078 to 0,085
from 0,055 to 0,062	from 0,062 to 0,069	from 0,069 to 0,076	from 0,076 to 0,082	from 0,082 to 0,089	from 0,089 to 0,099
from 0,061 to 0,069	from 0,069 to 0,078	from 0,078 to 0,087	from 0,087 to 0,095	from 0,095 to 0,104	from 0,104 to 0,116
79 x 149 x 259	79 x 149 x 259	79 x 149 x 259	79 x 149 x 259	79 x 149 x 259	79 x 149 x 259
660	660	660	660	660	660
230	230	230	230	230	230
115	115	115	115	115	115



from H 111 to H 140	from H 141 to H 170	from H 171 to H 200	from H 201 to H 230	from H 231 to H 260	from H 261 to H 300
100 x 100	100 x 100	100 x 100	100 x 100	100 x 100	100 x 100
12	12	12	12	12	12
10,164	10,164	10,164	10,164	10,164	10,164
from 99 to 128	from 129 to 158	from 159 to 188	from 189 to 218	from 219 to 248	from 249 to 288
from 0,043 to 0,046	from 0,046 to 0,049	from 0,049 to 0,051	from 0,051 to 0,054	from 0,054 to 0,057	from 0,057 to 0,060
from 0,053 to 0,059	from 0,059 to 0,065	from 0,065 to 0,070	from 0,070 to 0,076	from 0,076 to 0,082	from 0,082 to 0,088
110 x 110 x 254	110 x 110 x 254	110 x 110 x 254	110 x 110 x 254	110 x 110 x 254	110 x 110 x 254
700	700	700	700	700	700
70	70	70	70	70	70
70	70	70	70	70	70

Pressure at the bottom of the structure

Referred to the Atlantis System 50x50 cm of h 100 cm with Ø 110 mm pipe

Hypotesis of load ⁽¹⁾ kg/m ²	Slab thickness cm	Mesh Ø mm cmxcm	Thickness of the lean concrete cm	Pressure at pillar base ⁽²⁾ kg/cm ²
3.000	4	Ø5 20 x 20	5	1,90
			10	0,70
			15	0,40
5.000	5	Ø6 20 x 20	10	1,10
			15	0,60
			20	0,30
10.000	6	Ø8 20 x 20	10	2,10
			15	1,10
			20	0,60
15.000	8	Ø8 15 x 15	15	1,60
			20	0,90
			25	0,60
20.000	10	Ø8 15 x 15	15	2,10
			20	1,30
			25	0,80

Referred to the Atlantis System 71x71 cm of h 100 cm with Ø 125 mm pipe

Hypotesis of load ⁽¹⁾ kg/m ²	Slab thickness cm	Mesh Ø mm cmxcm	Thickness of the lean concrete cm	Pressure at pillar base ⁽²⁾ kg/cm ²
1.000	5	Ø8 20 x 20	5	1,20
			10	0,50
			15	0,20
2.000	6	Ø8 15 x 15	5	2,20
			10	0,80
			15	0,40
4.000	8	Ø8 10 x 10	10	1,60
			15	0,80
			20	0,50
6.000	10	Double mesh Ø8 20 x 20	15	1,20
			20	0,70
			25	0,50
15.000	15	Double mesh Ø8 15 x 15	20	1,80
			25	1,20
			30	0,90

Referred to the Atlantis System 100x100 cm of h 100 cm with Ø 160 mm pipe

Hypotesis of load ⁽¹⁾ kg/m ²	Slab thickness cm	Mesh Ø mm cmxcm	Thickness of the lean concrete cm	Pressure at pillar base ⁽²⁾ kg/cm ²
500	5	Ø8 20 x 20	5	1,20
			10	0,50
			15	0,20
1.000	7	Ø8 20 x 20	5	2,10
			10	0,80
			15	0,40
2.000	10	Double mesh Ø8 20 x 20	10	1,50
			15	0,80
			20	0,50
5.000	15	Double mesh Ø8 20 x 20	15	1,90
			20	1,20
			25	0,80
10.000	20	Double mesh Ø10 20 x 20	20	2,30
			25	1,50
			30	1,10

⁽¹⁾ Characteristical values.

⁽²⁾ Project values.

The indicated overloads are those normally in use while the actual flow rates are much higher. The table expresses, starting from the various examples of overload and of thickness (to be given to the slab), the pressures that would be applied to the feet of the structure, in relation to the (eventual) thicknesses of the lean concrete.

Installation method (Images and schemes referred to Atlantis 50x50 cm with Ø 110 mm pipe)



The Atlantis System is made up of three basic elements in its standard configuration: Atlantis formwork h 16 cm (A), pipe (B) diameter 110 mm (external) and variable height, foot (C).

In order to plug the formworks laid against the wall, it is suggested to use the Tympanum accessory. The Atlantis formworks are simple to install: the procedure consists of inserting the pipe into the slip-on base and then linking the Atlantis formwork to the far end of the pipe using the bayonet coupling. Each piece can be hooked to the adjacent piece thanks to the shaped grooves for the male/female linking.

For this, simply position them in horizontal rows from the left to the right, with the arrow on the top turned outward from the operator, proceeding to the end of each row.

Thanks to the modularity and lightness of Atlantis, each operator will be able to position up to 30 sqm per hour standing comfortably in an erect position.

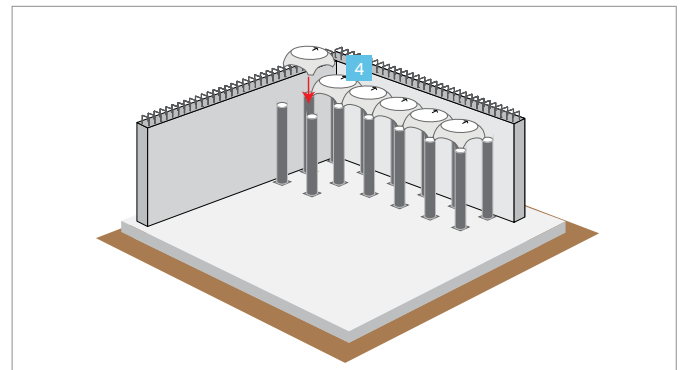
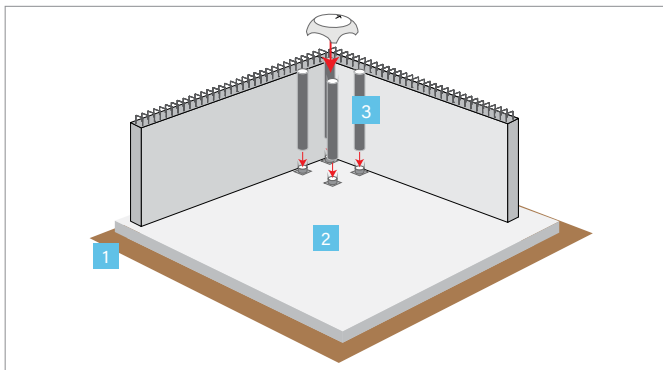

- 1 Preparation of the natural ground.
- 2 Preparation of the lean concrete foundation, to be sized according to the loads and capacity of the ground.
- 3 Pose of Atlantis system (foot+pipe+formwork)

- 4 Pose the elements from left to the right; once completed a row, proceed with next one.

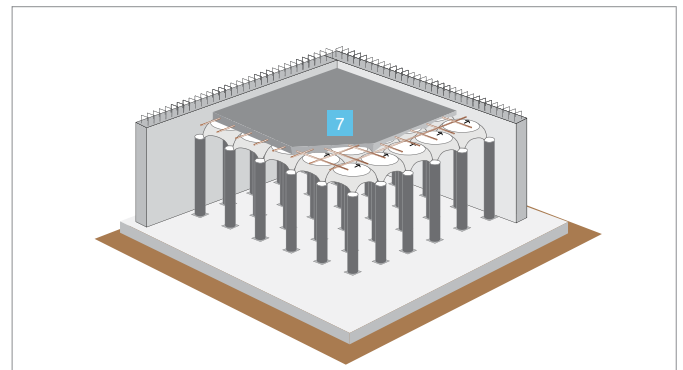
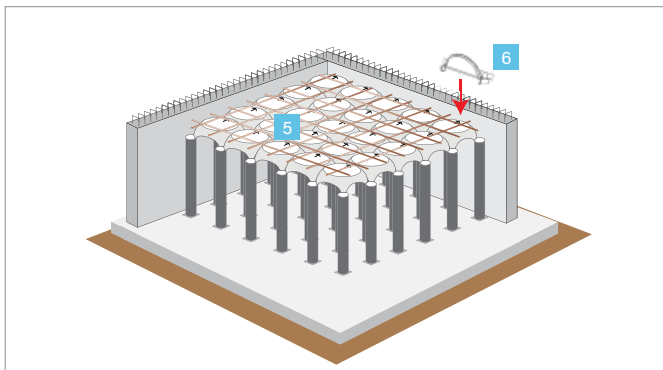

- 5 Laying the welded mesh Ø 6 20x20 above the formworks.
- 6 Insert the Tympanum accessory, between wall and formwork, along the cavity perimeter.

- 7 Realization of concrete casting, filling previously Atlantis pipes and then covering the formworks till reaching the quote of project.

To ensure a correct installation and perfectly created under-floor cavity please refer to the product's usage requirements.

Dry assembly method

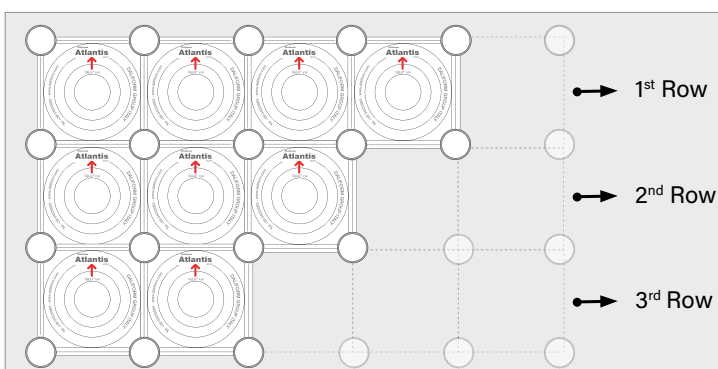

- 1 Position the first element to the upper left with respect to the work surface, making sure that the arrow is pointing up;

- 2 Unite the elements in sequence, by horizontal row, proceeding from the left towards the right and from the top downwards (following the direction normally used for writing), as shown graphically on the crown of each unit.

Accessories

Tympanum



The Tympanum is an accessory with compensation and occlusion function, to be used in combination with the wall or whenever necessary.

The Tympanum is equipped with flexible vertical slats to adhere perfectly to the wall even in the presence of roughness and irregularity of the latter.

The accessory is made of recycled PP (Alaplen®) and is available for all sizes of the Atlantis System: 50x50 cm; 71x71 and 100x100.



Tympanum for Atlantis System 50x50



Tympanum for Atlantis System 71x71



Tympanum for Atlantis System 100x100

Product for the system:	Piece weight (kg)	Pieces per box (pcs)	Pieces per pallet (pcs/PAL)	Pallet dimensions (cm)	Pallet weight (kg/PAL)
ATL 50	0,175	84	2.520	100 x 120 x 255	486
ATL 71 Ø110	0,245	28	672	100 x 120 x 217	210
ATL 71 Ø125	0,261	28	672	100 x 120 x 217	220
ATL 71 Ø140	0,271	28	672	100 x 120 x 217	230
ATL 100 Ø110	0,395	100	400	80 x 120 x 115	200
ATL 100 Ø160	0,457	72	288	80 x 120 x 115	180

Shelf



The Shelf is an accessory with compensation and occlusion function to be used whenever the dimensions of the intervention area do not correspond to an exact multiple of the Atlantis formwork measurements.

The Shelf accessory is made of recycled PP (Alaplen®) and is available for all sizes of the Atlantis System: 50x50 cm; 71x71 and 100x100.



Shelf for Atlantis System 50x50



Shelf for Atlantis System 71x71



Shelf for Atlantis System 100x100

Product for the system:	Piece weight (kg)	Pieces per box (pcs)	Pieces per pallet (pcs/PAL)	Pallet dimensions (cm)	Pallet weight (kg/PAL)
ATL 50	0,223	48	1.440	100 x 120 x 255	115
ATL 71	0,299	60	240	80 x 120 x 115	115
ATL 100	0,546	72	288	80 x 120 x 115	200

Angle



Angular occlusion element.

Universal element that adapts to all pipe diameters available in the Atlantis System.

The Angle element is made of recycled PP (Alaplen®) and is available for all sizes of the Atlantis System: 50x50 cm; 71x71 and 100x100.

Product for the system:	Piece weight (kg)	Pieces per box (pcs)	Pieces per pallet (pcs/PAL)	Pallet dimensions (cm)	Pallet weight (kg/PAL)
UNIVERSAL	0,020	300	9.600	110 x 110 x 191	226

Flange



The Flange is an accessory with reinforcement to compensation function. The accessory is made of recycled PP (Alaplen®) and is available for all sizes of the Atlantis System: 50x50 cm; 71x71 and 100x100, but only with the Ø 110 mm pipe.

Flange type:	Piece weight (kg)	Pieces per box (pcs)	Pieces per pallet (pcs/PAL)	Pallet dimensions (cm)	Pallet weight (kg/PAL)
FOR PIPE Ø 110 mm	0,588	17	510	110 x 110 x 191	344

Hook



The Hook is an accessory with reinforcement to compensation function. The accessory is made of recycled PP (Alaplen®) and is available for all sizes of the Atlantis System: 50x50 cm; 71x71 and 100x100.

Product for the system:	Piece weight (kg)	Pieces per box (pcs)	Pieces per pallet (pcs/PAL)	Pallet dimensions (cm)	Pallet weight (kg/PAL)
UNIVERSAL	0,099	80	2.560	110 x 110 x 255	283

Compensation panel



The Compensation panel is an accessory with compensation and occlusion function.

Dimensions (cm)	Thickness (cm)	Piece weight (kg)	Pieces per pallet (pcs/PAL)	M ² pallet (m ² /PAL)	Pallet dimensions (cm)	Pallet weight (kg/PAL)
200 x 500	1	2,000	200	200	200 x 110 x 120	420

Spacer



The Spacer is an accessory used to ensure the perpendicularity of the Atlantis System pipes.

The accessory is made of recycled PP (Alaplen®), is available for all sizes of the Atlantis System: 50x50 cm; 71x71 and 100x100 and it is usable only with the UNIVERSAL foot.

Product for the system:	Piece weight (kg)	Pieces per box (pcs)	Pieces per pallet (pcs/PAL)	Pallet dimensions (cm)	Pallet weight (kg/PAL)
ATL 50	0,042	360	9.840	100 x 120 x 217	461
ATL 71	0,068	270	6.480	110 x 120 x 217	490
ATL 100	0,105	180	4.320	110 x 120 x 217	501

The Atlantis System 50x50, for each square meter, needs 8 spacers.
The Atlantis System 71x71, for each square meter, needs 4 spacers.
The Atlantis System 100x100, for each square meter, needs 2 spacers.

Application example: deep, multi level foundations



The Atlantis System makes it possible to adjust the height of the elevator pipes within a centimetre, which can be supplied in different measurements. This will make it easy to quickly create structures at a low cost that require variable heights such as sloping ramps, slabs and multi-level slabs. Normally, slabs are created at the same height starting from the foundation bays that are on different levels (a classic example are "reversed T" beams or isolated foundations plinth), the Atlantis System makes it possible to easily create these structures without having to interrupt the regular placement of the formworks. The described system, if combined with the Muro formwork accessory, additionally reduces implementation times.

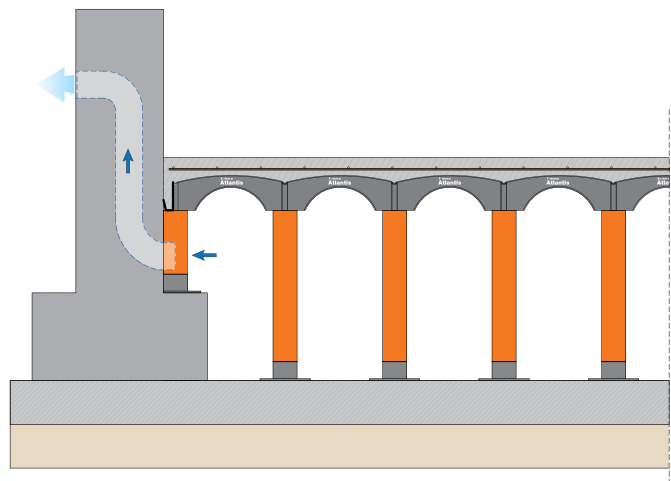

Application example: pool restructuring



It is known that a poorly dimensioned pool almost always causes operating problems, first of which is suitably heating the water at a reasonable cost. For this reason the bottom of the pool must sometimes be raised in order to reduce the volume of the water. A quick and economic solution to the problem, thanks to the high resistance, is to lift up the bottom using the Atlantis System.

The possibility to adjust the height of the elevator tube within a centimetre also makes it possible to easily create slopes in structures that have a finished bottom and surface inclined with different inclinations. The system can also be used for terracing.

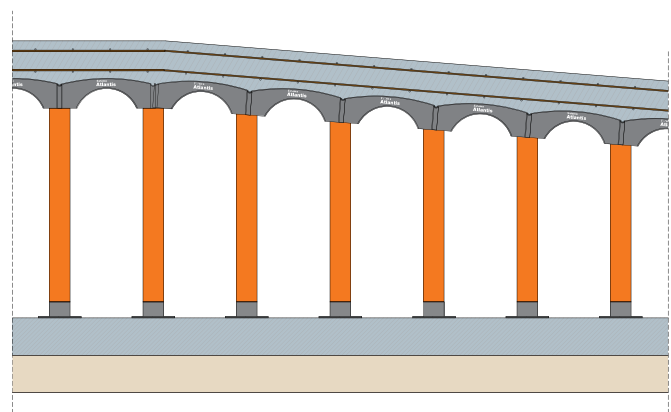

Application example: access ramps

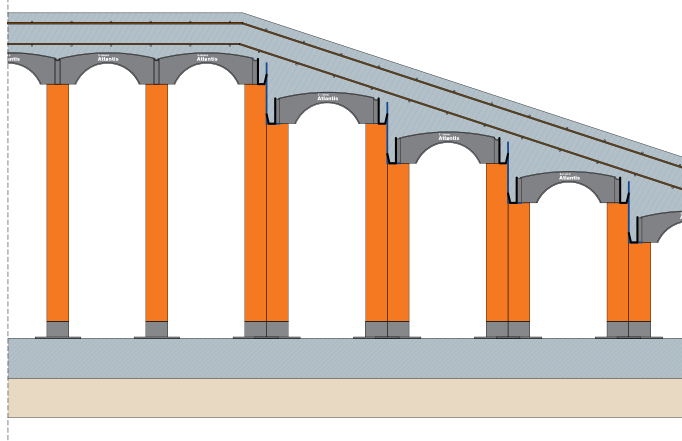

The Atlantis System makes it possible to quickly create ramps for accessing underground structures, with considerable savings in material use. In fact, instead of using materials such as sand, gravel or concrete, it is possible to create a foundation for the ramp that has the same height of the adjacent structure (parking area) and create a space with an inclined vehicle accessible slab on the top. The Atlantis System can also be used for curved ramps.

Daliform Group technicians are available to you to help you design your under-floor cavity, and upon request can provide customised studies with calculations and executive drawings.

Application example: formwork raft



The purpose of the foundation structures is to minimise deferred deformation due to the irregularity of the ground and asymmetric loads to ensure building stability. It is the two latter aspects that represent the true danger to the integrity of the foundation and the overlying structure. Once the type of foundation that is best suited for distributing the loads in the ground has been identified, based on the characteristics of the building and ground, the problem goes from being technical to economical, therefore the most economic solution must be identified for implementing the selected solution.

A solution to this problem, without changing the type of structure, is to create a box type raft (or formwork). This obtains a honeycomb structure consisting of two flat plates connected by mutually perpendicular beams: lower and upper slabs with a thickness of 15-20 cm with connection beams with a height of 70-120 cm positioned at variable centre distances

depending on static requirements. Thanks to the Iglu® or Atlantis formworks from the Daliform Group, in association with L-Plast panels or Muro formwork, it is possible to complete the raft structure in only two phases; that is casting the lower slab on which the Daliform Group products are positioned and then casting the beams and compression slab at the same time. This makes it possible to create extremely rigid foundations at a limited cost.

The main function of the foundation structures, such as the one proposed by the Atlantis System is to distribute the loads from the pillars, plates and walls to the ground and at the same time anchor the building to the ground, guaranteeing its stability. In some cases, always using the Atlantis System, foundation piles can be eliminated, which would instead be necessary with other construction solutions.

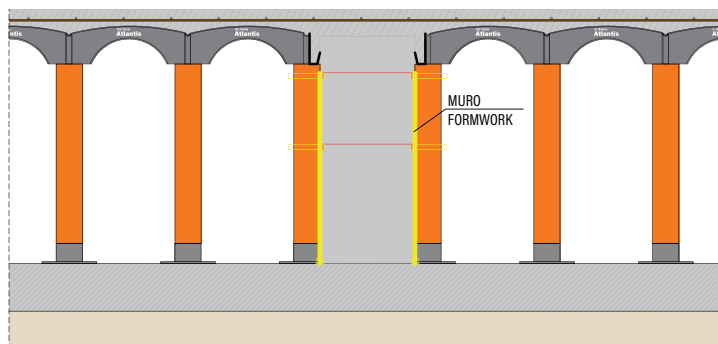

Compensation

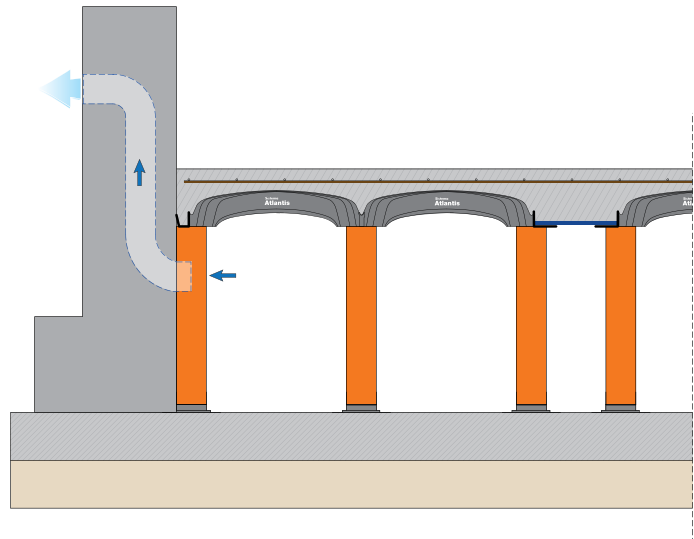

Construction details illustrating various solutions aimed at compensating structures in case that the internal dimensions of the crawl space are not exact multiples of the formwork Atlantis.

Certifications



- Technical Construction Certificate issued by the Technical and Test Institute for Constructions Prague (Czech Republic).
- Technical Construction Certificate issued by the Agency for Quality Control and Innovation in Building (Hungary).
- Hygienic Certificate issued by the National Institute of Hygiene (Poland).
- Acoustic check for the verification of DIN standards.
- Series of loading and breaking tests certified by the University of Padua.

Daliform Group technical office



FEASIBILITY STUDY

Predimensioning and optimisation of the structures, alternative and/or revised proposals, material and manpower estimates, cost analysis.
Evaluation of forced ventilation in the case of cold rooms.

CALCULATION REPORT

Reports certifying the execution of Daliform Group constructive systems.

SUPPORT FOR THE EXECUTIVE DESIGN

Support by design professionals. Upon request, the formwork positioning plan can be supplied with a list of the products required to carry out the work and the relative accessories.



ON-SITE SUPPORT

If necessary, our technical staff can be present on-site to help the construction company during the operational phase.

The technical consultancy is only valid for the Daliform Group construction systems.

To contact the technical office: Tel. +39 0422 2083 - tecnico@daliform.com

To obtain updated technical cards, support material, new photos and case studies, go to www.daliform.com

Photogallery



Istanbul Airport



Building for industrial use



Easy handling on site



Building for residential use



Mercedes Benz - New Jersey

Photogallery



Building for residential use



Building for industrial use



Building for residential use



Renovation of a train platform



Tree root protection (Waterblock Holland)



Atlantis system and Beton Up – monolithic slab supported by perimeter



Urban renovation



Airport



Rainwater accumulation tank



Building for industrial use



Renovation



Building for sanitary use

Specifications

Implementation of a ventilated under-ground cavity for a total height of _____ cm with the supply and on-site positioning of recycled plastic Atlantis System formworks from the Daliform Group, consisting of modular formworks positioned dry for the quick formation of a self-bearing pedestrian accessible platform above which the C25/30 concrete is cast to fill the formwork up to its crown and an upper slab of _____ cm reinforced with welded mesh Ø _____ cm 20 x 20 cm, levelled and smoothed with a trowel.

The Atlantis System shall be composed of recycled plastic formwork such as Iglu[®] with convex cover with dimensions 50x50 cm, h 16 cm and sustained by pipes Ø110 mm, di h _____ cm, complete with slip on bayonet connection feet, which can be walked on when dry, guaranteeing a breaking resistance of 200 kg in correspondence of the centre of the arch with an 8 x 8 cm clamp.

or

The Atlantis System shall be composed of recycled plastic formwork such as Iglu[®] with convex cover with dimensions 71x71 cm, h 15 cm and sustained by pipes Ø110 (or Ø125 or Ø140) mm, di h _____ cm, complete with slip on bayonet connection feet, which can be walked on when dry, guaranteeing a breaking resistance of 200 kg in correspondence of the centre of the arch with an 8 x 8 cm clamp.

or

The Atlantis System shall be composed of recycled plastic formwork such as Iglu[®] with convex cover with dimensions 100x100 cm, h 12 cm and sustained by pipes Ø110 (or Ø160) mm, di h _____ cm, complete with slip on bayonet connection feet, which can be walked on when dry, guaranteeing a breaking resistance of 200 kg in correspondence of the centre of the arch with an 8 x 8 cm clamp.

Formworks in recycled plastic, such as Iglu[®], for the formation of the Atlantis system, must be made of "ALAPLEN[®] CP30", must not release polluting substances, have an Environmental Compatibility Certification and be produced by a Company Certified according to International Standards UNI EN ISO 9001 (Quality), UNI EN ISO 14001 (Environment); UNI EN ISO 45001 (Safety) and SA 8000 (Social responsibility).

The company that supplies the formworks such as Iglu[®], for the formation of the Atlantis system, must provide the technical and security sheet of the product and the granule "ALAPLEN[®] CP30" and also exhibit the product certificate approved by an EOTA (*European Organisation for Technical Approvals*) member agency.

Including accessories, waste, cutting and all other expenses: _____ /m² _____

Supply and installation cost grid







Sample referred to Atlantis system 100x100 cm having pipe Ø 110 mm

No.	Item	U.M.	Quantity	Unite price	Total
1	Supply of Atlantis formwork L 100 x L 100 x H 12 cm	m ²	1		
2	Supply of Ø 110 mm pipe with base	no.	4		
3	Dry positioning of the Atlantis system on the foundation	h/m ²	0,05		
4	Supply and positioning of the welded mesh Ø 6/20x20 cm	kg/m ²	2,328		
5	Supply and casting of concrete C25/30 - formwork up to the crown	m ³ /m ²	0,034		
6	Supply and casting of concrete C25/30 - filling of the pipes*	m ³ /m ²			
7	Supply and casting of concrete C25/30 - thickness upper slab	m ³ /m ²			

* 0,036 m³/m² per m of pipe

Total cost €/m²

Logistics - pallet capacity

MEANS OF TRANSPORT	NO. PALLET ATL 50x50	NO. PALLET ATL 71x71	NO. PALLET ATL 100x100	
Tractor (8,20/9,60x2,45)	14/16	15/18	14/16	
Trailer (6,20x2,45)	10	12	10	
Tractor + Trailer type "BIG" (8,40+7,20x2,45)	14+12	15+12	14+12	
Semi-trailer (13,60x2,45)	24	27	24	
20 feet container	10*	10*	10*	 20 feet
40 feet container	22*	24*	20*	 40 feet

* The m² per pallet can vary based on the type of container.

The information contained in this catalogue could be changed. Please request updated informations from DALIFORM GROUP, which reserves the right to make changes at any moment without notice. In consideration of recycled material, it is specified that there are tolerance margins caused by environmental factors.



www.daliform.com

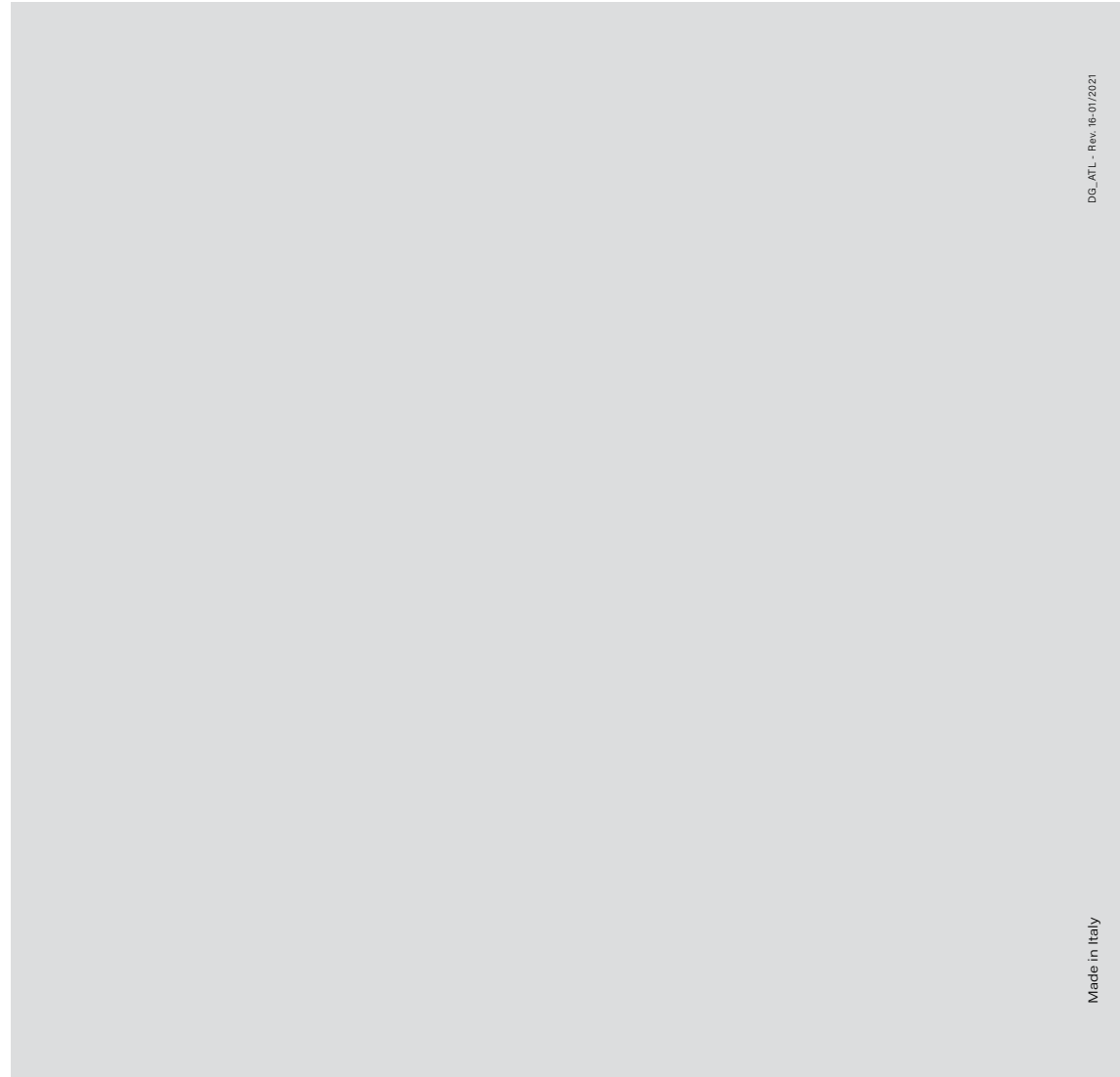

DG_ATL - Rev. 16-01/2021

Made in Italy

daliform
 GROUP
 Building Innovation © Creatori dell'Iglù®



Tel. +39 0422 2083 - Fax +39 0422 800234
 export@daliform.com - www.daliform.com
 Via Postumia Centro, 49 - 31040
 Gorgo al Monticano (TV) - Italy



Certified Management System UNI EN ISO 9001,
 UNI EN ISO 14001, UNI EN ISO 45001, SA 8000

Partner of
 GBC Italia

Rating di legalità: ★★+

