

CATALOGO
CATALOG
CATALOGUE
CATÁLOGO
KATALOG
ΚΑΤΑΛΟΓ



EUROCASSONETTO
il controtelaio per porte a scomparsa

®

*"Eletti sono coloro per i quali le cose belle
non hanno altro significato che di pura bellezza"*
Oscar Wilde

*"They are the elect to whom beautiful
things mean only Beauty"*
Oscar Wilde

*"Eleitos são aqueles para quem as coisas
belas apenas significam beleza"*
Oscar Wilde

*«Ce sont les élus pour qui les belles choses
signifient simplement la Beauté»*
Oscar Wilde

*«Los elegidos son aquellos para los que
las cosas bonitas no tienen más significado
que la propia belleza»*
Oscar Wilde

*"Ausgewählt werden diejenigen,
für die schöne Dinge keine andere Bedeutung
haben als reine Schönheit"*
Oscar Wilde

*«Избранные — те, для кого красивое
имеет одно значение красоты»*
Оскар Уайльд





"EUROCASSONETTO" amplia la sua gamma e si evolve "verso l'alto". In accordo con le nuove tendenze del moderno design, i controtelai per porte scorrevoli (ma non solo quelli) diventano gli attori principali di un nuovo concetto di architettura.

Minimalismo, essenzialità, pulizia delle linee diventano i concetti chiave che trasformano un elemento architettonico in un complemento d'arredo. Ciò succede quando la tecnica si fonde con l'eleganza.



"EUROCASSONETTO" expands its range and grows "upwards". In line with the new trends in modern design, counter-frames for sliding doors (but not only) become the main protagonists of a new concept of architecture.

Minimalism, simplicity and a clean look are the key concepts that transform an architectural element into a furnishing accessory. This is what happens when technology blends with elegance.



"EUROCASSONETTO" amplia a sua gama e evolui "em altura". Seguindo as novas tendências do design moderno, os caixilhos para portas de correr (e não só) tornaram-se os atores principais de um novo conceito de arquitetura.

O minimalismo, a essencialidade e a pureza das linhas erigem-se como conceitos-chave que transformam um elemento arquitetónico num complemento decorativo.

Isso acontece quando a técnica se funde com a elegância.



«EUROCASSONETTO» élargit sa gamme et évolue «vers le haut». En accord avec les nouvelles tendances du design moderne, les contre-châssis pour portes coulissantes (mais pas seulement ces derniers) deviennent les principaux acteurs d'un nouveau concept d'architecture.

Minimalisme, essentialisme, pureté des lignes deviennent les concepts clés qui transforment un élément architectural en un accessoire déco. Cela se produit lorsque la technique se confond avec l'élégance.



«EUROCASSONETTO» amplia su gama y evoluciona «hacia arriba». Siguiendo las nuevas tendencias del diseño moderno, los contramarcos para puertas correderas (pero no solo para estas) se transforman en protagonistas de un nuevo concepto de arquitectura. Minimalismo, carácter esencial, líneas limpias constituyen actualmente conceptos clave que transforman un elemento arquitectónico en un complemento de decoración.

Esto ocurre cuando la técnica se fusiona con la elegancia.



"EUROCASSONETTO" erweitert sein Angebot und entwickelt sich "nach oben".

Entsprechend den neuen Trends des modernen Designs werden die Gegenrahmen für Schiebetüren (aber nicht nur diese) zu Hauptakteuren eines neuen Architekturkonzepts.

Minimalismus, Wesentlichkeit und klare Linien werden zu Schlüsselkonzepten, die ein architektonisches Element in einen Einrichtungsgegenstand verwandeln.

Dies geschieht, wenn die Technik mit Eleganz verschmilzt.



"EUROCASSONETTO" расширяет свой ассортимент, делая прогресс в своем развитии.

Согласно новым тенденциям современного дизайна, кассеты для раздвижных дверей (и не только) превращаются в главные элементы новой концепции архитектуры.

Минимализм, сущность, чистота линий становятся ключевыми концепциями, преобразуя архитектурный элемент в предмет обстановки. Это возможно тогда, когда техника работает в симбиозе с элегантностью.

MAGNIFIKO

 La porta, maestosa, scorre e scompare all'interno di "Magnifiko", il controtelaio "a tutta altezza" di Eurocassonetto con predisposizione per le sole cornici laterali.

Nota tecnica: la particolare struttura del binario in alluminio consente alla porta di essere incapsulata all'interno del falso telaio.

 The majestic door slides and disappears inside "Magnifiko", the "full height" sliding door system by Eurocassonetto designed only with side frames.

Technical note: the unique structure of the aluminium track means the door can be encapsulated inside the false frame.

 A porta, majestosa, desliza e desaparece no interior do "Magnifiko", o caixilho "à altura" da Eurocassonetto predisposto apenas para as molduras laterais.

Nota técnica: a estrutura especial do binário em alumínio permite que a porta seja encapsulada dentro do quadro falso.

 La porte, majestueuse, glisse et disparaît dans « Magnifiko », le contre-châssis qui s'étend sur toute la hauteur d'Eurocassonetto et aménagé pour recevoir les cadres latéraux.

Remarque technique : la structure spéciale des rails en aluminium permet à la porte de disparaître complètement dans le faux-châssis.

 La puerta, majestuosa, se desliza y desaparece dentro de «Magnifiko», el contramarco «de altura completa» de Eurocassonetto con ajuste para marcos laterales.

Nota técnica: la particular estructura del riel de aluminio permite que la puerta se acople en el interior del falso marco.

 Die majestätische Tür gleitet und verschwindet in "Magnifiko", dem Gegenrahmen "in voller Höhe" von Eurocassonetto, der nur für die Seitenrahmen gedacht ist.

Technischer Hinweis: Durch die besondere Struktur der Aluminiumschiene kann die Tür in den Zwischenrahmen eingekapselt werden.

 Величественная дверь перемещается и уходит в "Magnifiko", кассету во всю высоту стены Eurocassonetto с возможностью установки только боковых наличников.

Техническое примечание: особая конструкция алюминиевой направляющей позволяет устанавливать дверь в фальш-коробку.



EUROCASSONETTO MAGNIFIKO

AD UN'ANTA INTONACO • ONE DOOR PLASTER • UMA PORTA REBOCO
 À UN VANTAIL ENDUIT • UNA HOJA ENLUCIDO • EINEM FLÜGEL PUTZ
 один Створки штукатурку

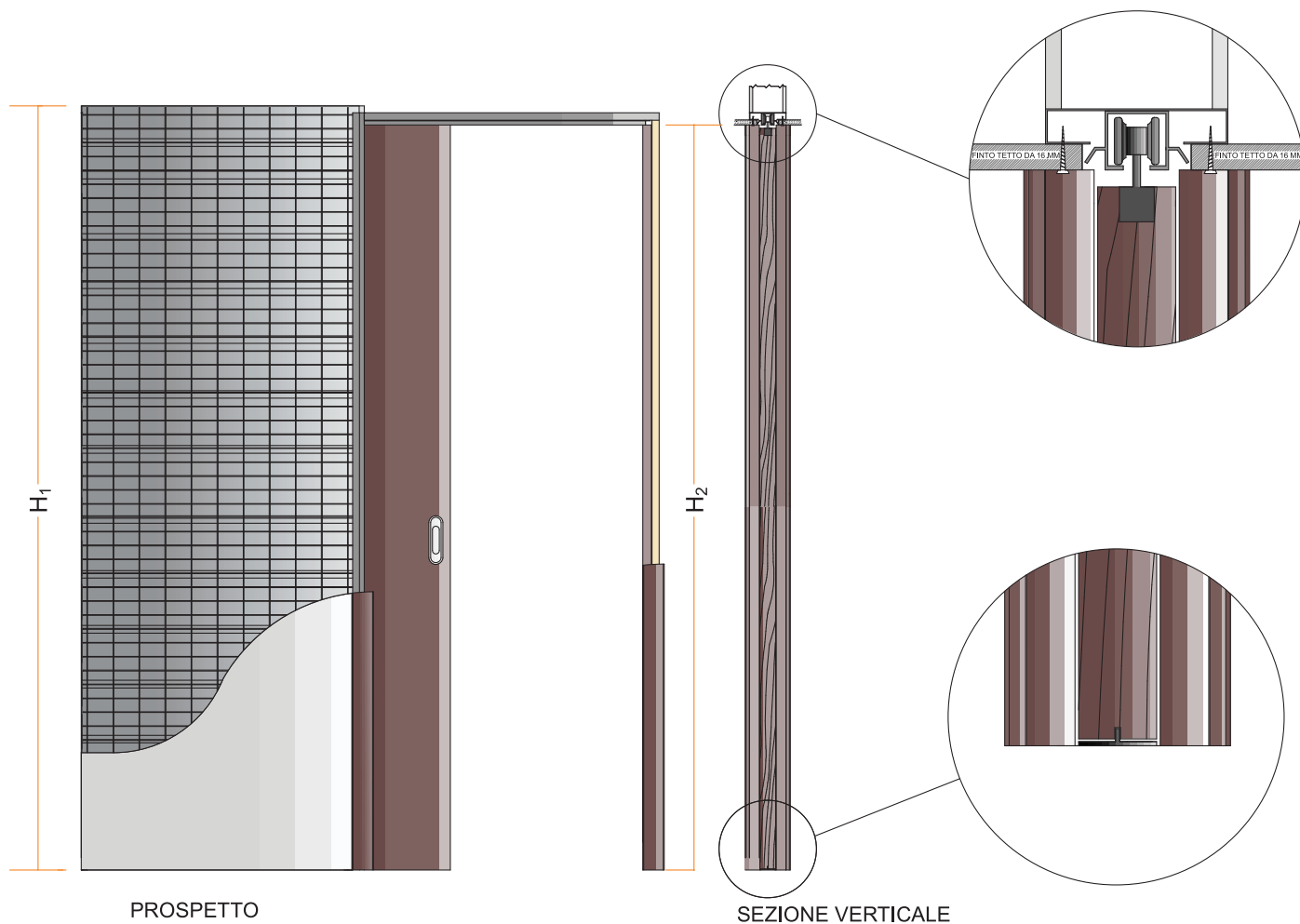

PROSPETTO

SEZIONE VERTICALE

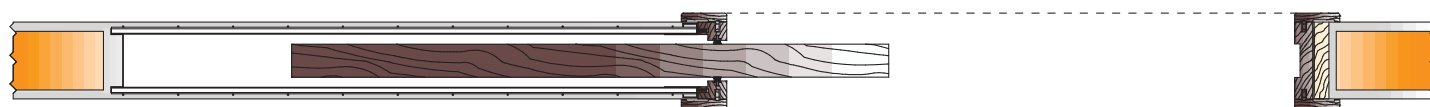

SEZIONE ORIZZONTALE

PROSPETTO • VIEW • PROSPECTO • VUE • VISTA • SCHNITT • Вид
 SEZIONE VERTICALE • VERTICAL SECTION • SEÇÃO VERTICAL • COUPE VERTICALE • SECCIÓN VERTICAL • VERTIKAL SCHNITT • ВЕРТИКАЛЬНЫЙ РАЗДЕЛ
 SEZIONE ORIZZONTALE • HORIZONTAL SECTION • SEÇÃO HORIZONTAL • COUPE HORIZONTAL • SECCIÓN HORIZONTAL • HORIZONTALER SCHNITT • ГОРИЗОНТАЛЬНЫЙ РАЗДЕЛ

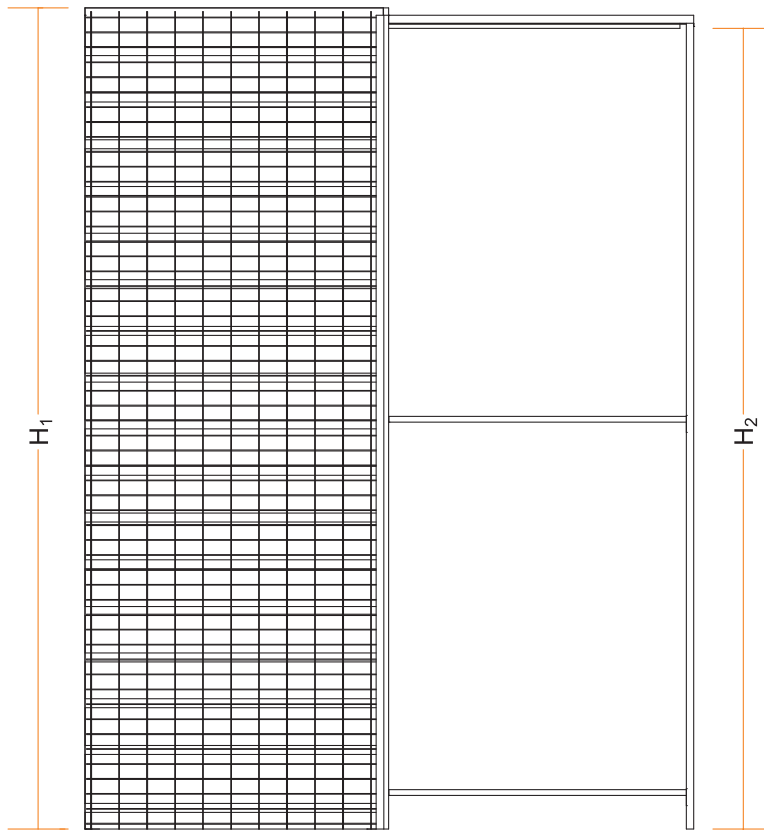

PROSPETTO

S_e	S_i
90	54
105	69
125	89

S_e = Spessore Parete Finita
 S_i = Sede interna

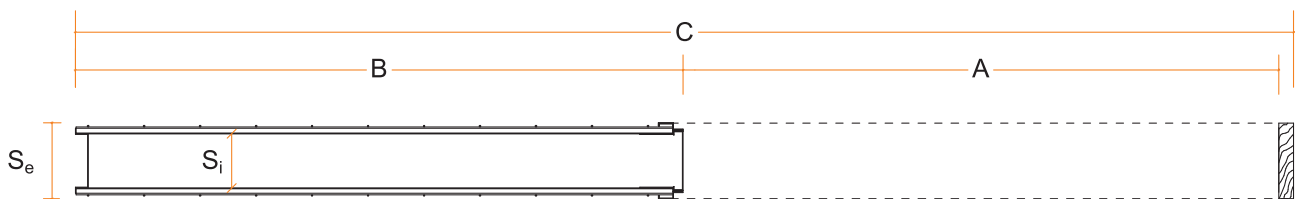

SEZIONE ORIZZONTALE

COD.	A	B	C	H ₁	H ₂	Misura porta LxH
E 60x230/240/250 MK INT (S_e)	645	635	1300	2365/2465/2565	2310/2410/2510	610x2300/2400/2500
E 70x230/240/250 MK INT (S_e)	745	735	1500	2365/2465/2565	2310/2410/2510	710x2300/2400/2500
E 80x230/240/250 MK INT (S_e)	845	835	1700	2365/2465/2565	2310/2410/2510	810x2300/2400/2500
E 90x230/240/250 MK INT (S_e)	945	935	1900	2365/2465/2565	2310/2410/2510	910x2300/2400/2500
E 100x230/240/250 MK INT (S_e)	1045	1035	2100	2365/2465/2565	2310/2410/2510	1010x2300/2400/2500
E 110x230/240/250 MK INT (S_e)	1145	1135	2300	2365/2465/2565	2310/2410/2510	1110x2300/2400/2500
E 120x230/240/250 MK INT (S_e)	1245	1235	2500	2365/2465/2565	2310/2410/2510	1210x2300/2400/2500

Se = Spessore parete finita • Total thickness • Espesura parede acabada • Épaisseur totale • Espesor total • Gesamtstärke • ВСЕГО ТОЛЩИНА СТЕНЫ

Si = sede interna • Internal housing • Parte interna • Logement intérieur • Sede interior • Sitz innen • ВНУТРЕННИЙ ЖИЛЬЕ

PROSPETTO • VIEW • ПРОСПЕКТ • VUE • VISTA • SCHNITT • Вид

SEZIONE ORIZZONTALE • HORIZONTAL SECTION • SEÇÃO HORIZONTAL • COUPE HORIZONTAL • SECCIÓN HORIZONTAL • HORIZONTALER SCHNITT • ГОРИЗОНТАЛЬНЫЙ РАЗДЕЛ

A = Luce lorda; B = Larghezza controtelaio; C = Larghezza complessiva; H1 = Altezza controtelaio; H2 = Altezza lorda

A = Total Light; B = Counterframe Width; C = Total Width; H1 = Counterframe Height; H2 = Total Height

A = Abertura Bruta; B = Largura Caixa; C = Largura Total; H1 = Altura Caixa; H2 = Altura Bruta;

A = Largeur ouverture brute; B = Largeur contre-châssis; C = Largeur totale; H1 = Hauteur contre-châssis; H2 = Hauteur brute;

A = Sección tránsito bruta; B = Ancho contromarco; C = Ancho total; H1 = Altura contromarco; H2 = Altura bruta;

A = Max ausmaße; B = Breite Blindstock; C = Gesamtbreite; H1 = Hohe Blindstock; H2 = Max hohe

EUROCASSONETTO MAGNIFIKO

DOPPIO INTONACO • DOUBLE PLASTER
 DUPLO REBOCO • DOUBLE ENDUIT
 DOBLE ENLUCIDO • DOPPELTEN PUTZ
 двойной штукатурку

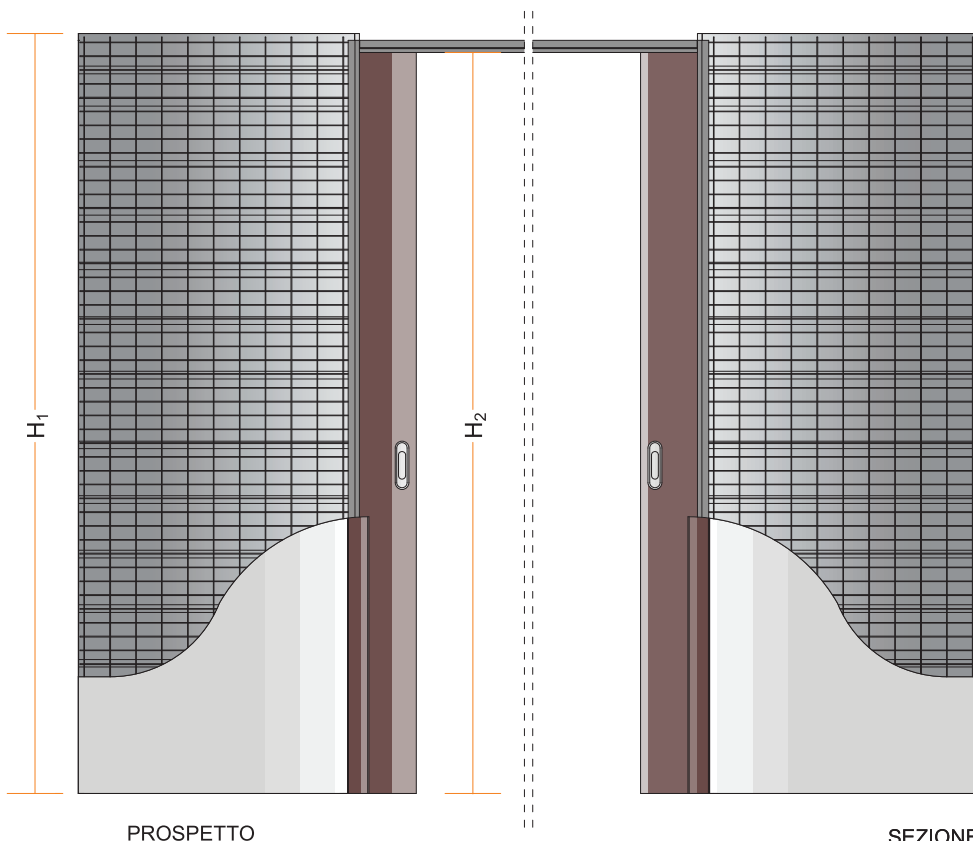

PROSPETTO

SEZIONE VERTICALE

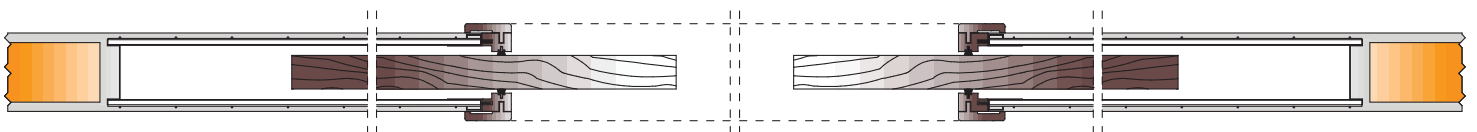
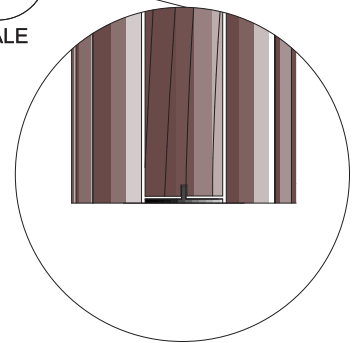
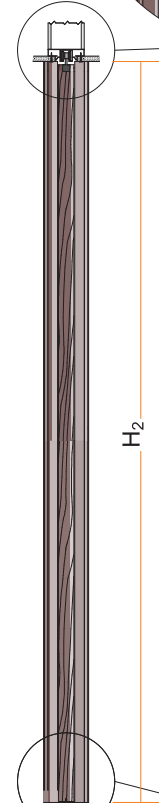
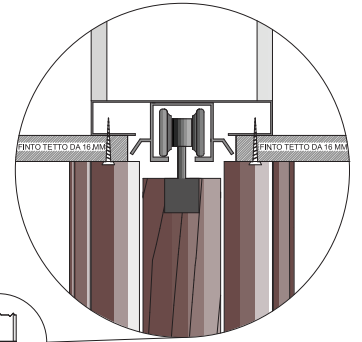

SEZIONE ORIZZONTALE

PROSPETTO • VIEW • PROSPECTO • VUE • VISTA • SCHNITT • Вид

SEZIONE VERTICALE • VERTICAL SECTION • SEÇÃO VERTICAL • COUPE VERTICALE • SECCIÓN VERTICAL • VERTIKAL SCHNITT • ВЕРТИКАЛЬНЫЙ РАЗДЕЛ

SEZIONE ORIZZONTALE • HORIZONTAL SECTION • SEÇÃO HORIZONTAL • COUPE HORIZONTAL • SECCIÓN HORIZONTAL • HORIZONTALER SCHNITT • ГОРИЗОНТАЛЬНЫЙ РАЗДЕЛ

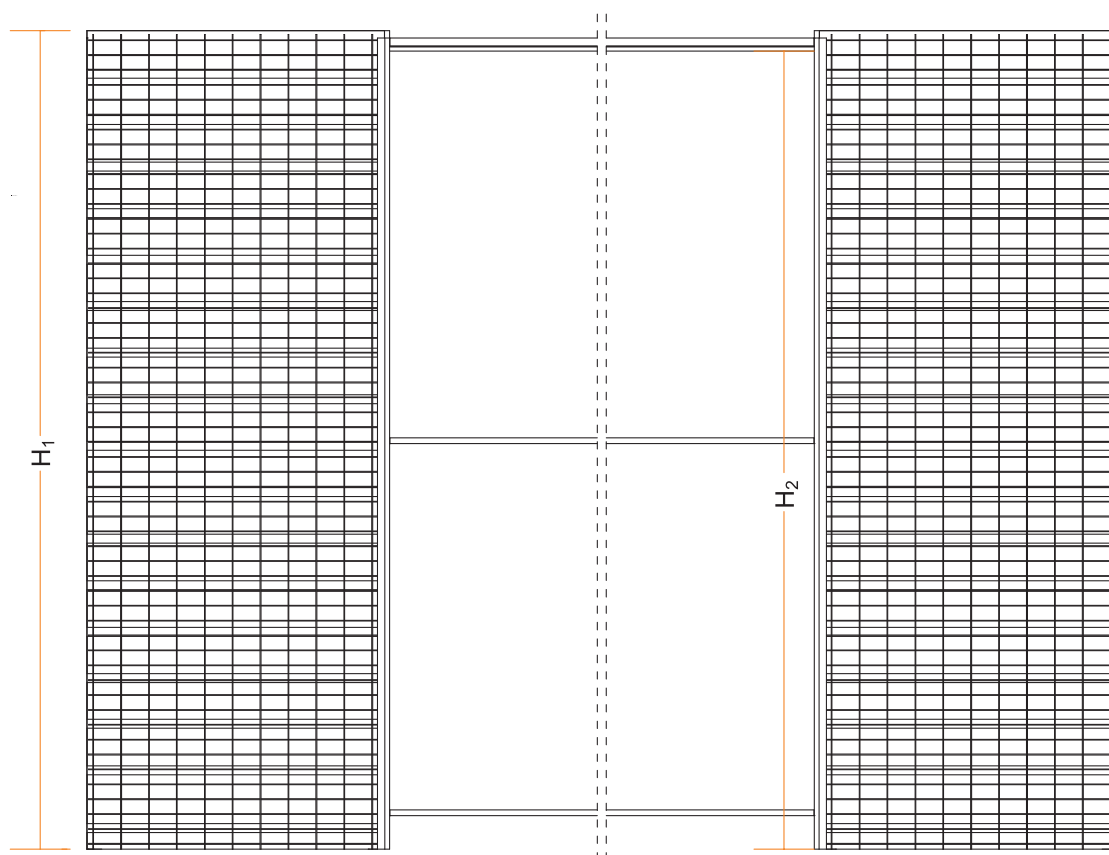

PROSPETTO

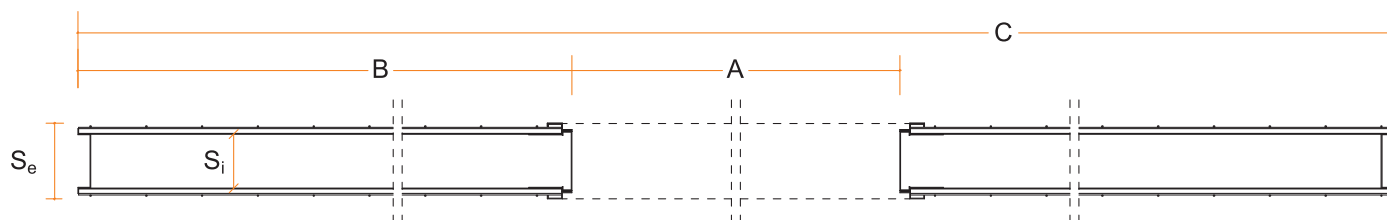

SEZIONE ORIZZONTALE

COD.	A	B	C	H_1	H_2	Misura porta LxH
E 60x230/240/250 MK D INT. (S_e)	1230	635	2500	2365/2465/2565	2310/2410/2510	N°2 610x2300/2400/2500
E 70x230/240/250 MK D INT. (S_e)	1430	735	2900	2365/2465/2565	2310/2410/2510	N°2 710x2300/2400/2500
E 80x230/240/250 MK D INT. (S_e)	1630	835	3300	2365/2465/2565	2310/2410/2510	N°2 810x2300/2400/2500
E 90x230/240/250 MK D INT. (S_e)	1830	935	3700	2365/2465/2565	2310/2410/2510	N°2 910x2300/2400/2500
E 100x230/240/250 MK D INT. (S_e)	2030	1035	4100	2365/2465/2565	2310/2410/2510	N°2 1010x2300/2400/2500
E 110x230/240/250 MK D INT. (S_e)	2230	1135	4500	2365/2465/2565	2310/2410/2510	N°2 1110x2300/2400/2500
E 120x230/240/250 MK D INT. (S_e)	2430	1235	4900	2365/2465/2565	2310/2410/2510	N°2 1210x2300/2400/2500

Se = Spessore parete finita • Total thickness • Espesura parede acabada • Épaisseur totale • Espesor total • Gesamtstärke • ВСЕГО ТОЛЩИНА СТЕНЫ

Si = sede interna • Internal housing • Parte interna • Logement intérieur • Sede interior • Sitz innen • ВНУТРЕННИЙ ЖИЛЬЕ

PROSPETTO • VIEW • ПРОСПЕКТ • VUE • VISTA • SCHNITT • Вид

SEZIONE ORIZZONTALE • HORIZONTAL SECTION • SEÇÃO HORIZONTAL • COUPE HORIZONTAL • SECCIÓN HORIZONTAL • HORIZONTALER SCHNITT • ГОРИЗОНТАЛЬНЫЙ РАЗДЕЛ

A = Luce lorda; **B** = Larghezza controtelaio; **C** = Larghezza complessiva; **H1** = Altezza controtelaio; **H2** = Altezza lorda

A = Total Light; B = Counterframe Width; C = Total Width; H1 = Counterframe Height; H2 = Total Height

A = Abertura Bruta; B = Largura Caixaíto; C = Largura Total; H1 = Altura Caixaíto; H2 = Altura Bruta;

A = Largeur ouverture brute; B = Largeur contre-châssis; C = Largeur totale; H1 = Hauteur contre-châssis; H2 = Hauteur brute;

A = Sección tránsito bruta; B = Ancho contramarco; C = Ancho total; H1 = Altura contramarco; H2 = Altura bruta;

A = Max ausmaße; B = Breite Blindstock; C = Gesamtbreite; H1 = Hohe Blindstock; H2 = Max hohe

EUROCASSONETTO MAGNIFIKO

AD UN'ANTA CARTONGESSO • ONE DOOR DRYWALL
 UMA PORTA GESSO ACARTONADO • À UN VANTAIL PLACOPLÂTRE
 UNA HOJA YESO LAMINADO • EINEM FLÜGEL GIPSKARTON
 один Створки гипсокартон

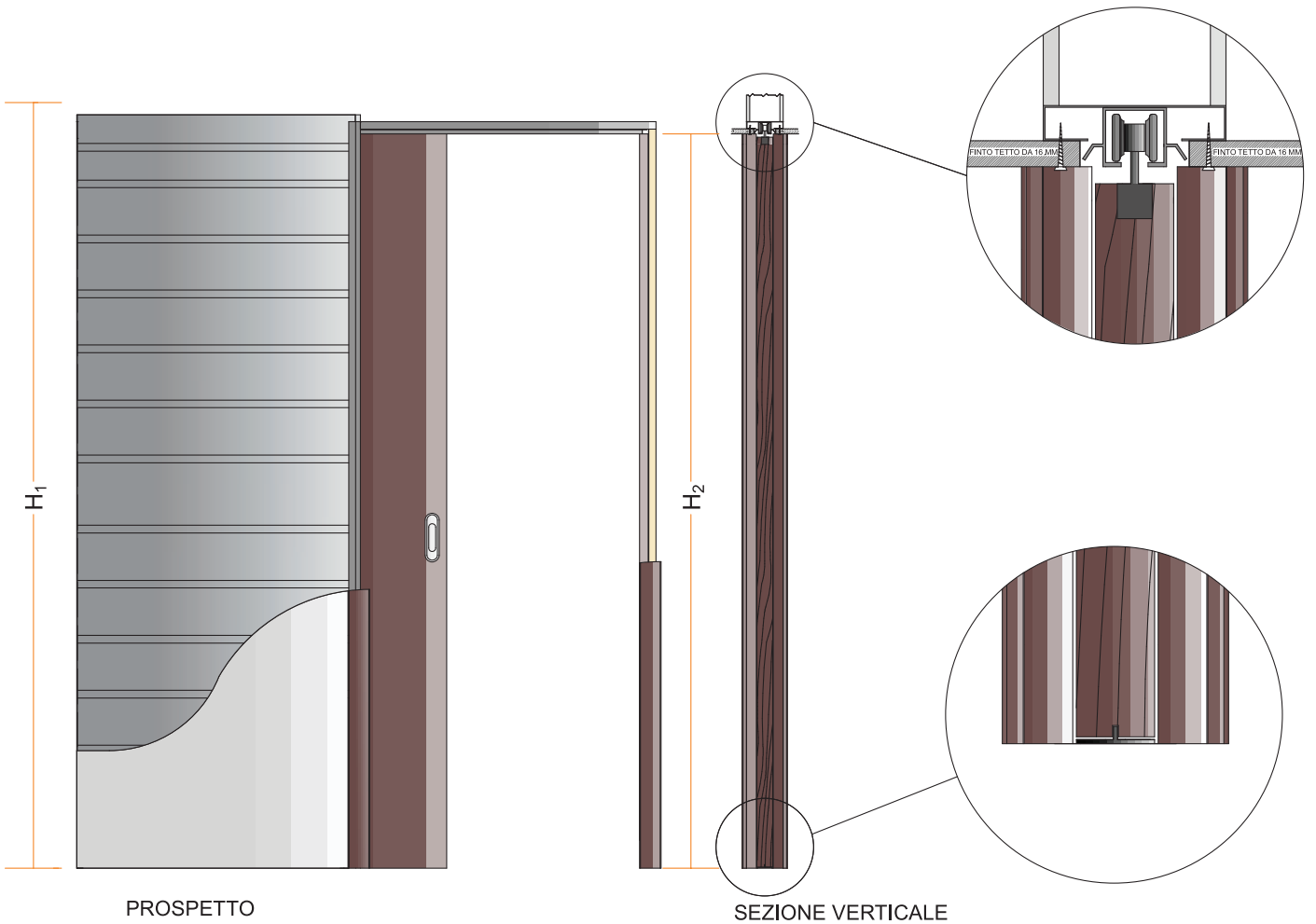

PROSPETTO

SEZIONE VERTICALE

SEZIONE ORIZZONTALE

PROSPETTO • VIEW • PROSPECTO • VUE • VISTA • SCHNITT • Вид

SEZIONE VERTICALE • VERTICAL SECTION • SEÇÃO VERTICAL • COUPE VERTICALE • SECCIÓN VERTICAL • VERTIKAL SCHNITT • ВЕРТИКАЛЬНЫЙ РАЗДЕЛ

SEZIONE ORIZZONTALE • HORIZONTAL SECTION • SEÇÃO HORIZONTAL • COUPE HORIZONTAL • SECCIÓN HORIZONTAL • HORIZONTALER SCHNITT • ГОРИЗОНТАЛЬНЫЙ РАЗДЕЛ

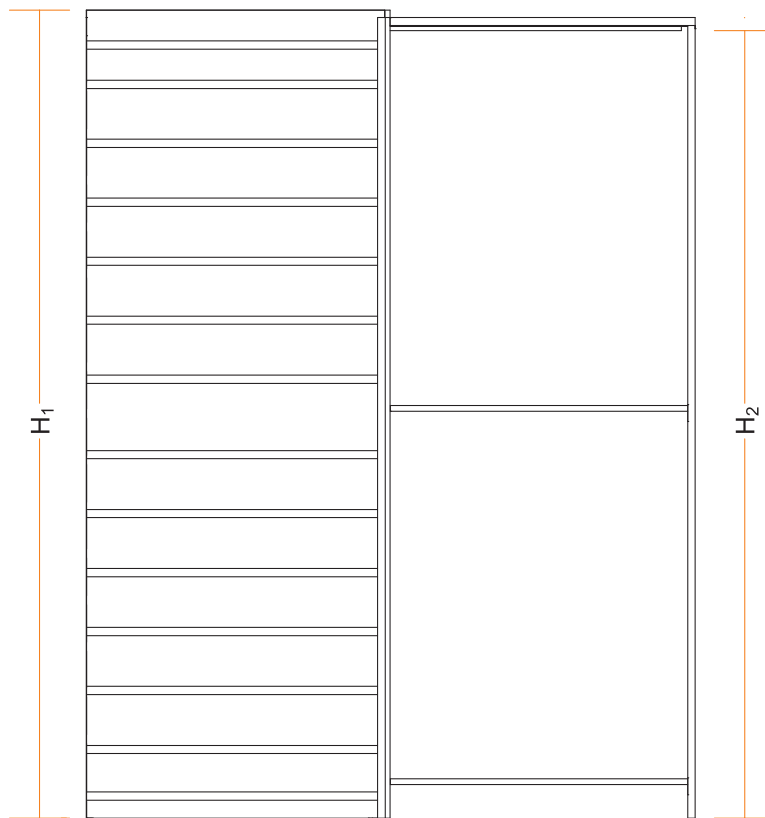

PROSPETTO

S_e	S_i
90	54
100	62
125	87

S_e = Spessore Parete Finita
 S_i = Sede interna

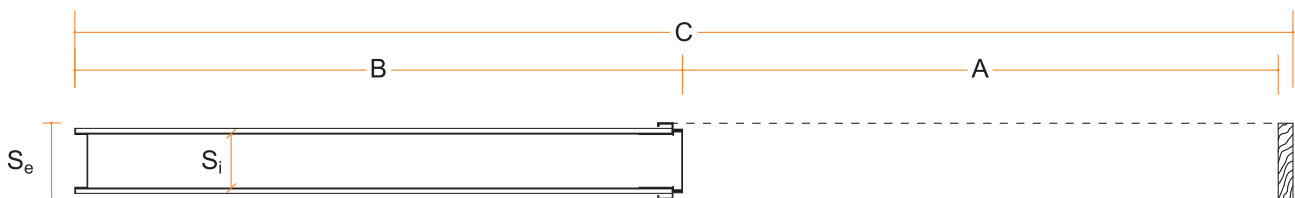

SEZIONE ORIZZONTALE

COD.	A	B	C	H_1	H_2	Misura porta LxH
E 60x230/240/250 MK CTG (S_e)	645	635	1300	2365/2465/2565	2310/2410/2510	610x2300/2400/2500
E 70x230/240/250 MK CTG (S_e)	745	735	1500	2365/2465/2565	2310/2410/2510	710x2300/2400/2500
E 80x230/240/250 MK CTG (S_e)	845	835	1700	2365/2465/2565	2310/2410/2510	810x2300/2400/2500
E 90x230/240/250 MK CTG (S_e)	945	935	1900	2365/2465/2565	2310/2410/2510	910x2300/2400/2500
E 100x230/240/250 MK CTG (S_e)	1045	1035	2100	2365/2465/2565	2310/2410/2510	1010x2300/2400/2500
E 110x230/240/250 MK CTG (S_e)	1145	1135	2300	2365/2465/2565	2310/2410/2510	1110x2300/2400/2500
E 120x230/240/250 MK CTG (S_e)	1245	1235	2500	2365/2465/2565	2310/2410/2510	1210x2300/2400/2500

Se = Spessore parete finita • Total thickness • Espesura parede acabada • Épaisseur totale • Espesor total • Gesamtstärke • ВСЕГО ТОЛЩИНА СТЕНЫ

Si = sede interna • Internal housing • Parte interna • Logement intérieur • Sede interior • Sitz innen • ВНУТРЕННИЙ ЖИЛЬЕ

PROSPETTO • VIEW • ПРОСПЕКТ • VUE • VISTA • SCHNITT • Вид

SEZIONE ORIZZONTALE • HORIZONTAL SECTION • SEÇÃO HORIZONTAL • COUPE HORIZONTAL • SECCIÓN HORIZONTAL • HORIZONTALER SCHNITT • ГОРИЗОНТАЛЬНЫЙ РАЗДЕЛ

A = Luce lorda; B = Larghezza controtelaio; C = Larghezza complessiva; H1 = Altezza controtelaio; H2 = Altezza lorda

A = Total Light; B = Counterframe Width; C = Total Width; H1 = Counterframe Height; H2 = Total Height

A = Abertura Bruta; B = Largura Caixa; C = Largura Total; H1 = Altura Caixa; H2 = Altura Bruta;

A = Largeur ouverture brute; B = Largeur contre-châssis; C = Largeur totale; H1 = Hauteur contre-châssis; H2 = Hauteur brute;

A = Sección tránsito bruta; B = Ancho contromarco; C = Ancho total; H1 = Altura contromarco; H2 = Altura bruta;

A = Max ausmaße; B = Breite Blindstock; C = Gesamtbreite; H1 = Hohe Blindstock; H2 = Max hohe

EUROCASSONETTO MAGNIFIKO

DOPPIO CARTONGESSO • DOUBLE DRYWALL
 DUPLO GESSO ACARTONADO
 DOUBLE PLACOPLÂTRE
 DOBLE YESO LAMINADO
 DOPPELTEN GIPSKARTON
 двойной гипсокартон

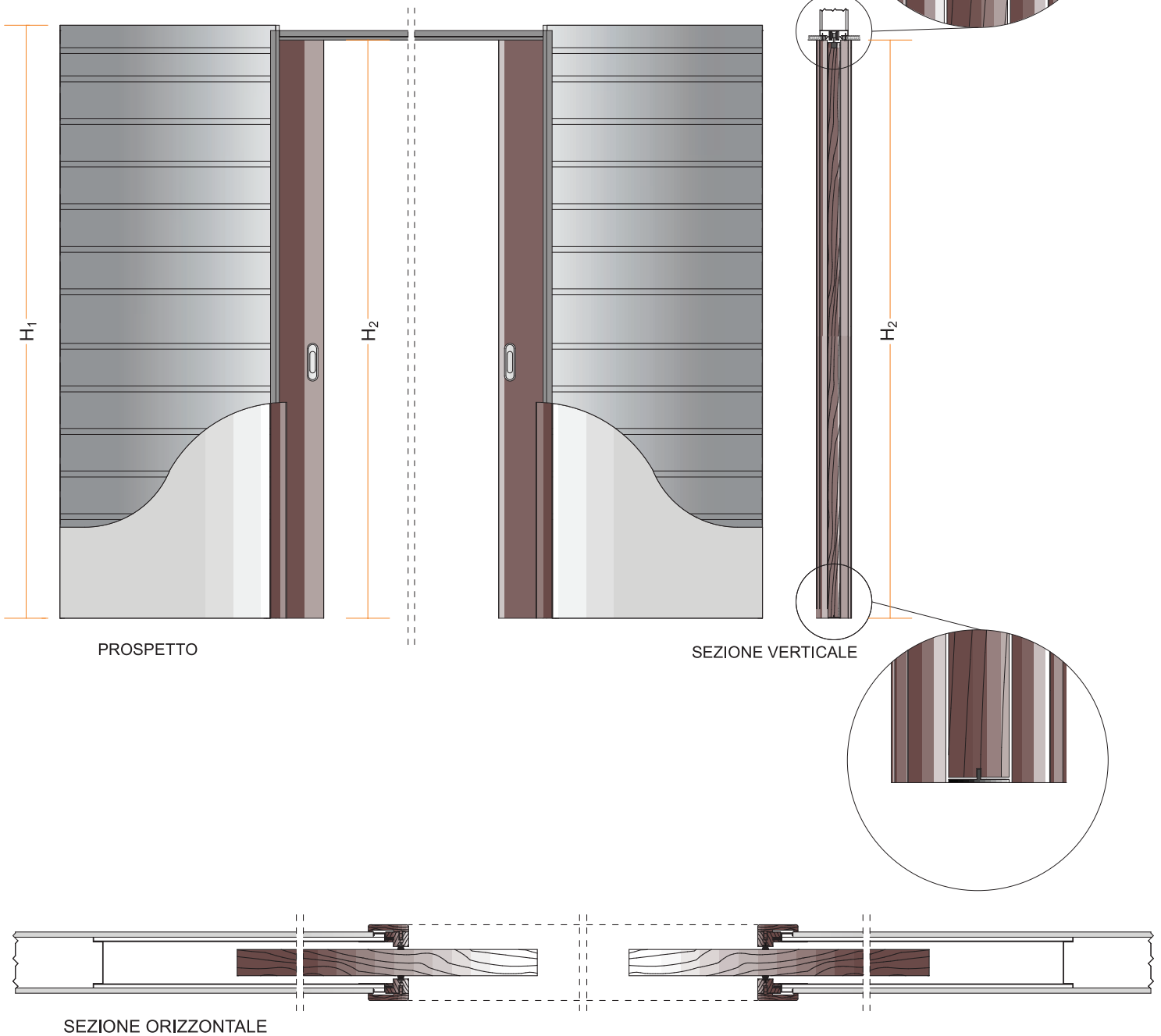

PROSPETTO • VIEW • PROSPECTO • VUE • VISTA • SCHNITT • Вид

SEZIONE VERTICALE • VERTICAL SECTION • SEÇÃO VERTICAL • COUPE VERTICALE • SECCIÓN VERTICAL • VERTIKAL SCHNITT • ВЕРТИКАЛЬНЫЙ РАЗДЕЛ

SEZIONE ORIZZONTALE • HORIZONTAL SECTION • SEÇÃO HORIZONTAL • COUPE HORIZONTAL • SECCIÓN HORIZONTAL • HORIZONTALER SCHNITT • ГОРИЗОНТАЛЬНЫЙ РАЗДЕЛ

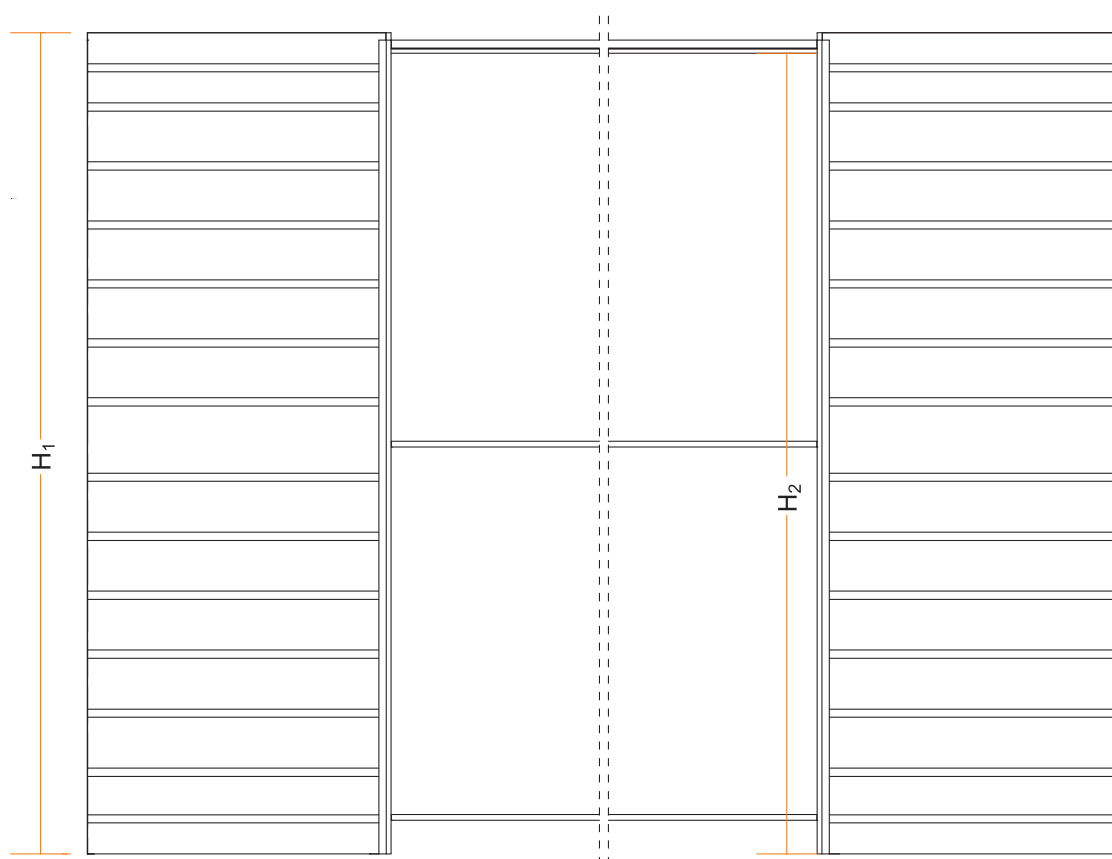

S_e	S_i
90	54
100	62
125	87

S_e = Spessore Parete Finita
 S_i = Sede interna

PROSPETTO

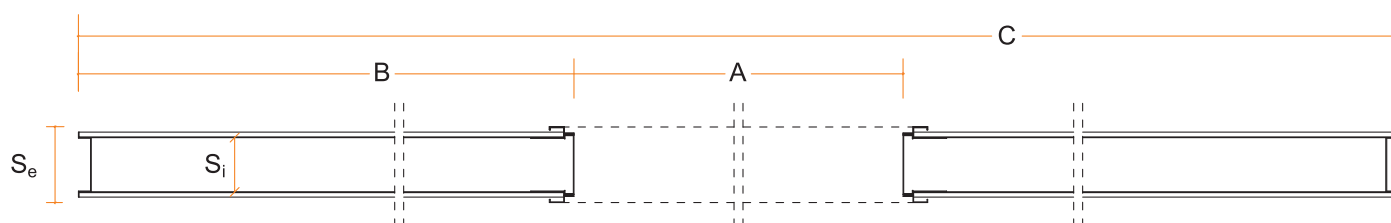

SEZIONE ORIZZONTALE

COD.	A	B	C	H_1	H_2	Misura porta LxH
E 60x230/240/250MK D CTG. (S_e)	1230	635	2500	2365/2465/2565	2310/2410/2510	N°2 610x2300/2400/2500
E 70x230/240/250MK D CTG. (S_e)	1430	735	2900	2365/2465/2565	2310/2410/2510	N°2 710x2300/2400/2500
E 80x230/240/250MK D CTG. (S_e)	1630	835	3300	2365/2465/2565	2310/2410/2510	N°2 810x2300/2400/2500
E 90x230/240/250MK D CTG. (S_e)	1830	935	3700	2365/2465/2565	2310/2410/2510	N°2 910x2300/2400/2500
E 100x230/240/250MK D CTG. (S_e)	2030	1035	4100	2365/2465/2565	2310/2410/2510	N°2 1010x2300/2400/2500
E 110x230/240/250MK D CTG. (S_e)	2230	1135	4500	2365/2465/2565	2310/2410/2510	N°2 1110x2300/2400/2500
E 120x230/240/250MK D CTG. (S_e)	2430	1235	4900	2365/2465/2565	2310/2410/2510	N°2 1210x2300/2400/2500

Se = Spessore parete finita • Total thickness • Espesura parede acabada • Épaisseur totale • Espesor total • Gesamtstärke • ВСЕГО ТОЛЩИНА СТЕНЫ

Si = sede interna • Internal housing • Parte interna • Logement intérieur • Sede interior • Sitz innen • ВНУТРЕННИЙ ЖИЛЬЕ

PROSPETTO • VIEW • ПРОСПЕКТ • VUE • VISTA • SCHNITT • Вид

SEZIONE ORIZZONTALE • HORIZONTAL SECTION • SEÇÃO HORIZONTAL • COUPE HORIZONTAL • SECCIÓN HORIZONTAL • HORIZONTALER SCHNITT • ГОРИЗОНТАЛЬНЫЙ РАЗДЕЛ

A = Luce lorda; **B** = Larghezza controtelaio; **C** = Larghezza complessiva; **H1** = Altezza controtelaio; **H2** = Altezza lorda

A = Total Light; B = Counterframe Width; C = Total Width; H1 = Counterframe Height; H2 = Total Height

A = Abertura Bruta; B = Largura Caixa; C = Largura Total; H1 = Altura Caixa; H2 = Altura Bruta;

A = Largeur ouverture brute; B = Largeur contre-châssis; C = Largeur totale; H1 = Hauteur contre-châssis; H2 = Hauteur brute;

A = Sección tránsito bruta; B = Ancho contramarco; C = Ancho total; H1 = Altura contramarco; H2 = Altura bruta;

A = Max ausmaße; B = Breite Blindstock; C = Gesamtbreite; H1 = Hohe Blindstock; H2 = Max hohe

FrameLess



L'evoluzione verso l'alto di FrameLess è "FrameLess Top": il controtelaio senza cornici e senza limiti di altezza.

Connubio di tecnica ed eleganza per una porta scorrevole a scomparsa sofisticata e minimalista.

Nota tecnica: la particolare struttura del binario in alluminio consente alla porta di essere incapsulata all'interno del falso telaio.



The advanced evolution of FrameLess is "FrameLess Top": the sliding door system without frames and without height limits.

A combination of technique and elegance are used to make a sophisticated and minimalist retractable sliding door.

Technical note: the unique structure of the aluminium track means the door can be encapsulated inside the false frame.



A evolução ascendente do FrameLess é o "FrameLess Top": o caixilho sem molduras e sem limites de altura.

Uma combinação de técnica e elegância para uma porta de correr retráctil, sofisticada e minimalista.

Nota técnica: a estrutura especial do binário em alumínio permite que a porta seja encapsulada dentro do quadro falso.



La version évoluée de FrameLess est « FrameLess Top » : le contre-châssis sans cadre et sans limite de hauteur.

Le parfait mélange de technique et d'élégance pour une porte coulissante escamotable, à la fois sophistiquée et minimaliste.

Remarque technique : la structure spéciale des rails en aluminium permet à la porte de disparaître complètement dans le faux-châssis.



La evolución hacia arriba de FrameLess es «FrameLess Top»: el contramarco sin marcos ni límites de altura.

Fusión de técnica y elegancia para una puerta corredera oculta sofisticada y minimalista.

Nota técnica: la particular estructura del riel de aluminio permite que la puerta se acople en el interior del falso marco.



Die Weiterentwicklung von FrameLess in der Höhe ist "FrameLess Top": der zargenlose Gegenrahmen ohne Höhenbeschränkungen.

Eine Kombination aus Technik und Eleganz für eine raffinierte und minimalistische Schiebetür.

Technischer Hinweis: Durch die besondere Struktur der Aluminiumschiene kann die Tür in den Zwischenrahmen eingekapselt werden.



С Новым более высоким вариантом FrameLess является "FrameLess Top" - кассета без наличников и без ограничений по высоте.

Союз техники и элегантности в изысканной минималистичной кассетной раздвижной двери.

Техническое примечание: особая конструкция алюминиевой направляющей позволяет устанавливать дверь в фальш-коробку.



EUROCASSONETTO FRAMELESS TOP

AD UN'ANTA INTONACO • ONE DOOR PLASTER • UMA PORTA REBOCO
 À UN VANTAIL ENDUIT • UNA HOJA ENLUCIDO • EINEM FLÜGEL PUTZ
 один Створки штукатурку

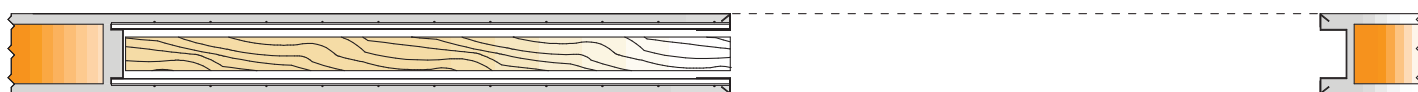
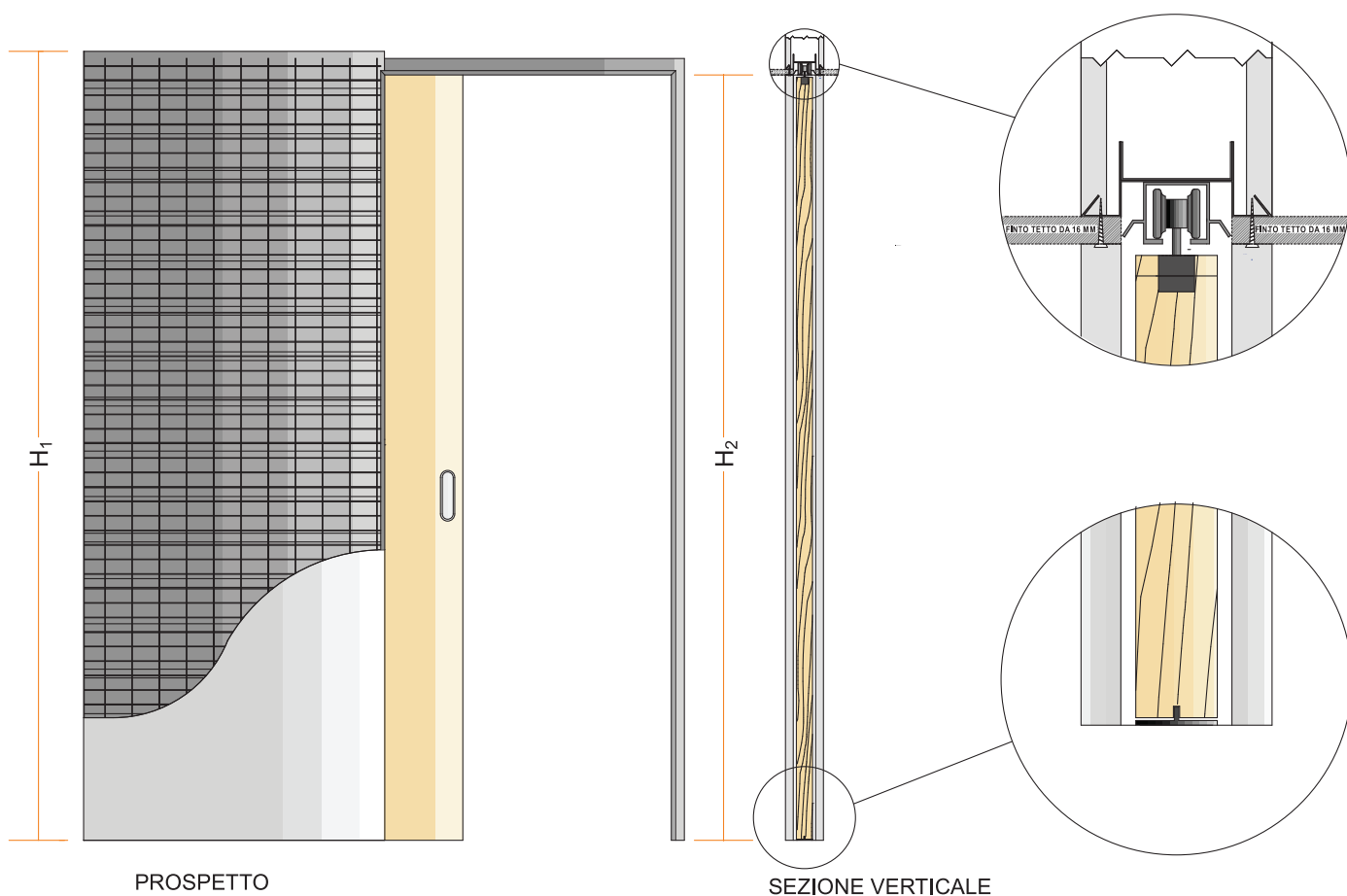

SEZIONE ORIZZONTALE

PROSPETTO • VIEW • PROSPECTO • VUE • VISTA • SCHNITT • Вид
 SEZIONE VERTICALE • VERTICAL SECTION • SEÇÃO VERTICAL • COUPE VERTICALE • SECCIÓN VERTICAL • VERTIKAL SCHNITT • ВЕРТИКАЛЬНЫЙ РАЗДЕЛ
 SEZIONE ORIZZONTALE • HORIZONTAL SECTION • SEÇÃO HORIZONTAL • COUPE HORIZONTAL • SECCIÓN HORIZONTAL • HORIZONTALER SCHNITT • ГОРИЗОНТАЛЬНЫЙ РАЗДЕЛ

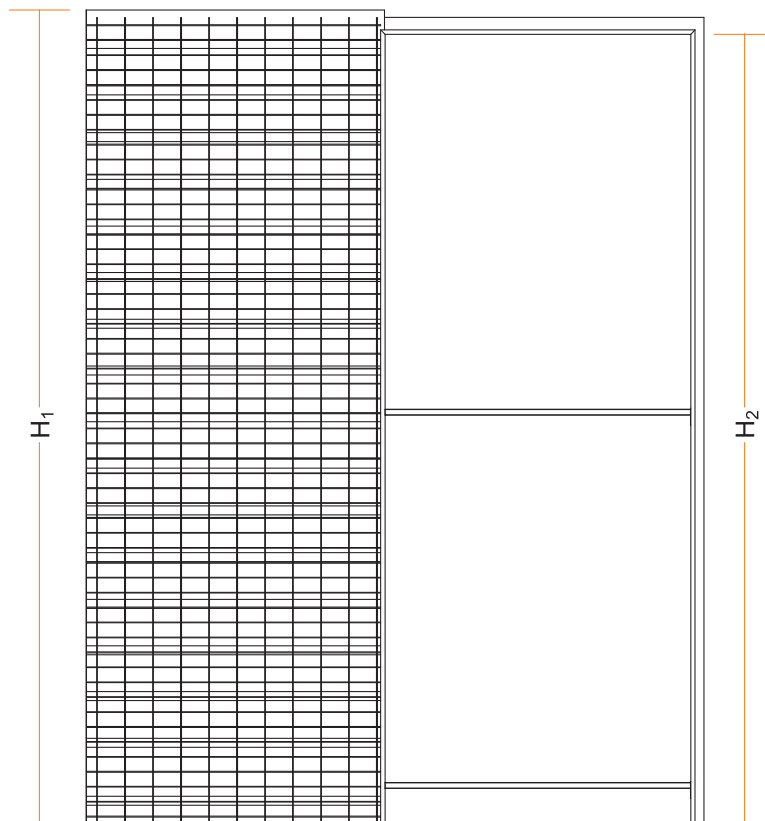

PROSPETTO

S_e	S_i
105	62

S_e = Spessore Parete Finita
 S_i = Sede interna

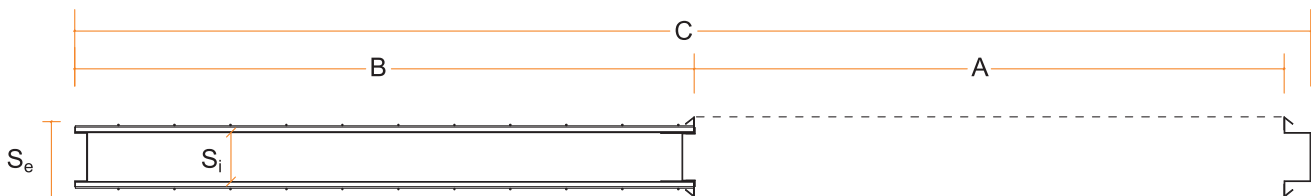

SEZIONE ORIZZONTALE

COD.	A	B	C	H ₁	H ₂	Misura porta LxH
E 60x230/240/250 FR T INT. (S_e)	590	630	1255	2375/2475/2575	2310/2410/2510	610x2300/2400/2500
E 70x230/240/250 FR T INT. (S_e)	690	730	1455	2375/2475/2575	2310/2410/2510	710x2300/2400/2500
E 80x230/240/250 FR T INT. (S_e)	790	830	1655	2375/2475/2575	2310/2410/2510	810x2300/2400/2500
E 90x230/240/250 FR T INT. (S_e)	890	930	1855	2375/2475/2575	2310/2410/2510	910x2300/2400/2500
E 100x230/240/250 FR T INT. (S_e)	990	1030	2055	2375/2475/2575	2310/2410/2510	1010x2300/2400/2500
E 110x230/240/250 FR T INT. (S_e)	1090	1130	2255	2375/2475/2575	2310/2410/2510	1110x2300/2400/2500
E 120x230/240/250 FR T INT. (S_e)	1190	1230	2455	2375/2475/2575	2310/2410/2510	1210x2300/2400/2500

Se = Spessore parete finita • Total thickness • Espesura parede acabada • Épaisseur totale • Espesor total • Gesamtstärke • ВСЕГО ТОЛЩИНА СТЕНЫ

Si = sede interna • Internal housing • Parte interna • Logement intérieur • Sede interior • Sitz innen • ВНУТРЕННИЙ ЖИЛЬЕ

PROSPETTO • VIEW • ПРОСПЕКТ • VUE • VISTA • SCHNITT • Вид

SEZIONE ORIZZONTALE • HORIZONTAL SECTION • SEÇÃO HORIZONTAL • COUPE HORIZONTAL • SECCIÓN HORIZONTAL • HORIZONTALER SCHNITT • ГОРИЗОНТАЛЬНЫЙ РАЗДЕЛ

A = Luce lorda; B = Larghezza controtelaio; C = Larghezza complessiva; H1 = Altezza controtelaio; H2 = Altezza lorda

A = Total Light; B = Counterframe Width; C = Total Width; H1 = Counterframe Height; H2 = Total Height

A = Abertura Bruta; B = Largura Caixa; C = Largura Total; H1 = Altura Caixa; H2 = Altura Bruta;

A = Largeur ouverture brute; B = Largeur contre-châssis; C = Largeur totale; H1 = Hauteur contre-châssis; H2 = Hauteur brute;

A = Sección tránsito bruta; B = Ancho contromarco; C = Ancho total; H1 = Altura contromarco; H2 = Altura bruta;

A = Max ausmaße; B = Breite Blindstock; C = Gesamtbreite; H1 = Hohe Blindstock; H2 = Max hohe

EUROCASSONETTO FRAMELESS TOP

DOPPIO INTONACO • DOUBLE PLASTER
 DUPLO REBOCO • DOUBLE ENDUIT
 DOBLE ENLUCIDO • DOPPELTEN PUTZ
 двойной штукатурку

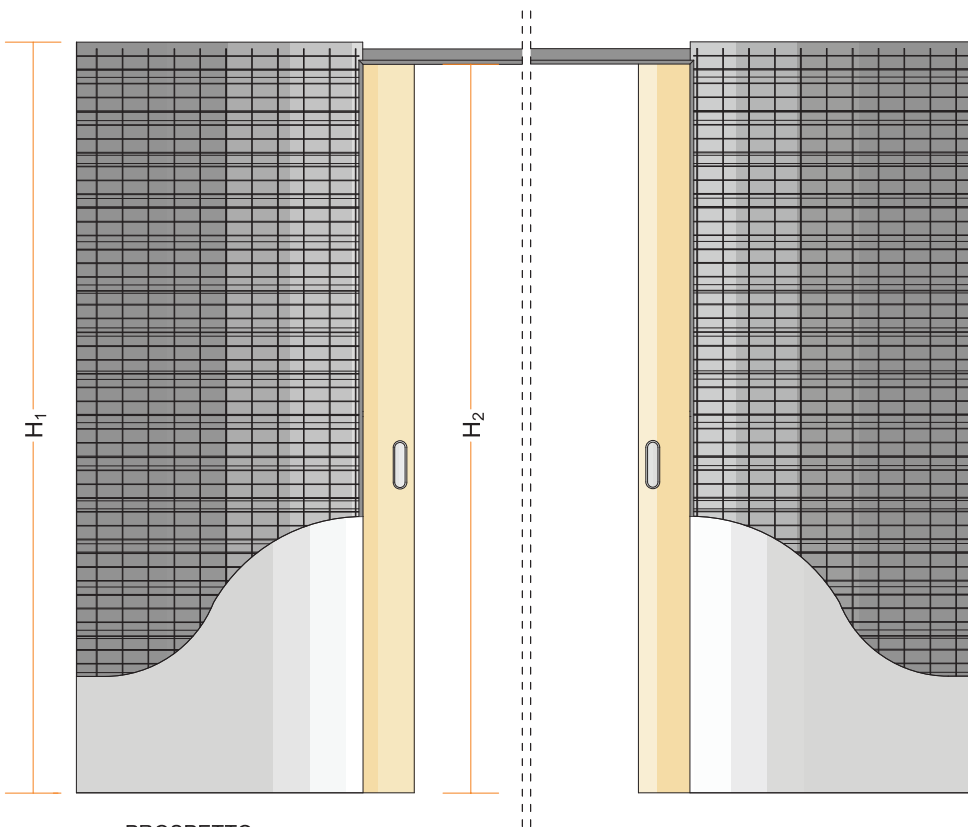
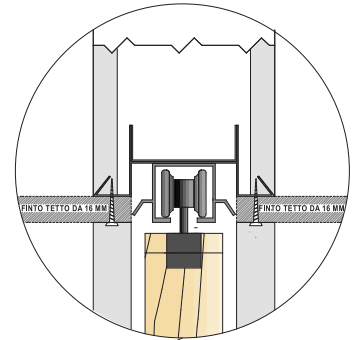

PROSPETTO

SEZIONE VERTICALE

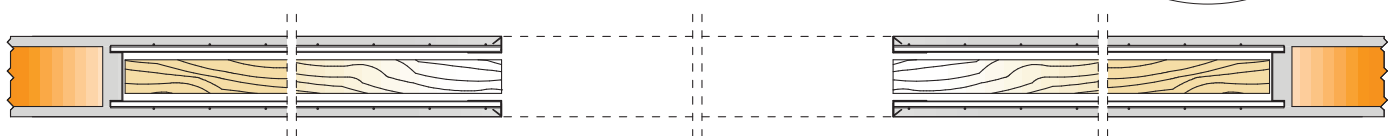
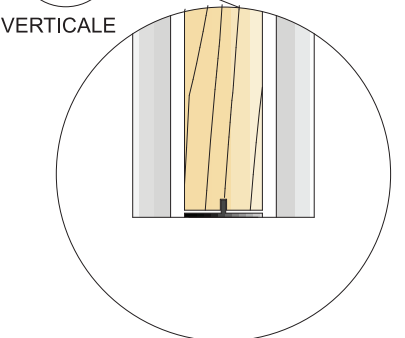

SEZIONE ORIZZONTALE

PROSPETTO • VIEW • PROSPECTO • VUE • VISTA • SCHNITT • Вид

SEZIONE VERTICALE • VERTICAL SECTION • SEÇÃO VERTICAL • COUPE VERTICALE • SECCIÓN VERTICAL • VERTIKAL SCHNITT • ВЕРТИКАЛЬНЫЙ РАЗДЕЛ

SEZIONE ORIZZONTALE • HORIZONTAL SECTION • SEÇÃO HORIZONTAL • COUPE HORIZONTAL • SECCIÓN HORIZONTAL • HORIZONTALER SCHNITT • ГОРИЗОНТАЛЬНЫЙ РАЗДЕЛ

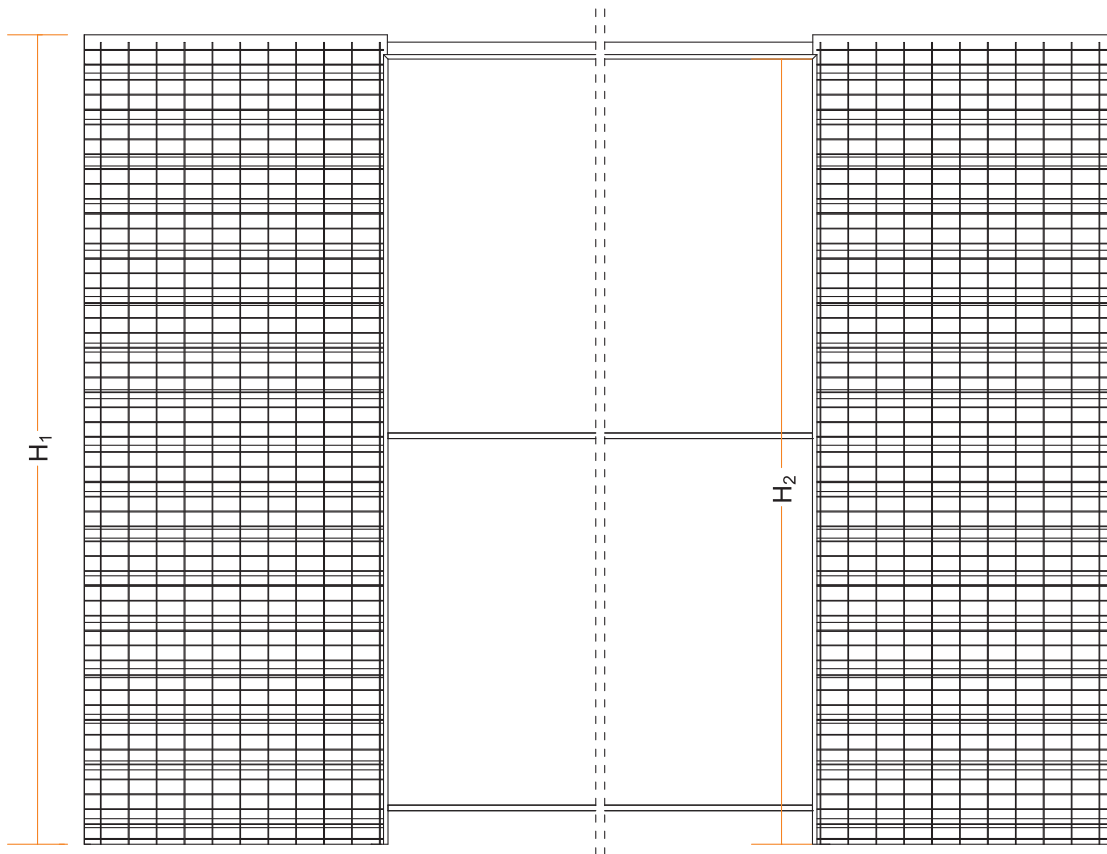

PROSPETTO

S_e	S_i
105	62

S_e = Spessore Parete Finita
 S_i = Sede interna

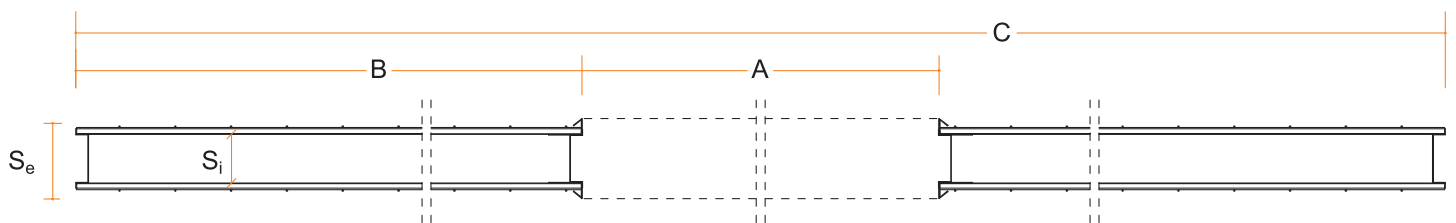

SEZIONE ORIZZONTALE

COD.	A	B	C	H_1	H_2	Misura porta LxH
E 60x230/240/250 FR T D INT. (S_e)	1190	630	2450	2365/2465/2565	2310/2410/2510	N°2 610x2300/2400/2500
E 70x230/240/250 FR T D INT. (S_e)	1390	730	2850	2365/2465/2565	2310/2410/2510	N°2 710x2300/2400/2500
E 80x230/240/250 FR T D INT. (S_e)	1590	830	3250	2365/2465/2565	2310/2410/2510	N°2 810x2300/2400/2500
E90x230/240/250 FR T D INT. (S_e)	1790	930	3650	2365/2465/2565	2310/2410/2510	N°2 910x2300/2400/2500
E100x230/240/250 FR T D INT. (S_e)	1990	1030	4050	2365/2465/2565	2310/2410/2510	N°2 1010x2300/2400/2500
E110x230/240/250 FR T D INT. (S_e)	2190	1130	4450	2365/2465/2565	2310/2410/2510	N°2 1110x2300/2400/2500
E120x230/240/250 FR T D INT. (S_e)	2390	1230	4850	2365/2465/2565	2310/2410/2510	N°2 1210x2300/2400/2500

Se = Spessore parete finita • Total thickness • Espesura parede acabada • Épaisseur totale • Espesor total • Gesamtstärke • ВСЕГО ТОЛЩИНА СТЕНЫ

Si = sede interna • Internal housing • Parte interna • Logement intérieur • Sede interior • Sitz innen • ВНУТРЕННИЙ ЖИЛЬЕ

PROSPETTO • VIEW • ПРОСПЕКТ • VUE • VISTA • SCHNITT • Вид

SEZIONE ORIZZONTALE • HORIZONTAL SECTION • SEÇÃO HORIZONTAL • COUPE HORIZONTALE • SECCIÓN HORIZONTAL • HORIZONTALER SCHNITT • ГОРИЗОНТАЛЬНЫЙ РАЗДЕЛ

A = Luce lorda; **B** = Larghezza controtelaio; **C** = Larghezza complessiva; **H1** = Altezza controtelaio; **H2** = Altezza lorda

A = Total Light; B = Counterframe Width; C = Total Width; H1 = Counterframe Height; H2 = Total Height

A = Abertura Bruta; B = Largura Caixaího; C = Largura Total; H1 = Altura Caixaího; H2 = Altura Bruta;

A = Largeur ouverture brute; B = Largeur contre-châssis; C = Largeur totale; H1 = Hauteur contre-châssis; H2 = Hauteur brute;

A = Sección tránsito bruta; B = Ancho contromarco; C = Ancho total; H1 = Altura contromarco; H2 = Altura bruta;

A = Max ausmaße; B = Breite Blindstock; C = Gesamtbreite; H1 = Höhe Blindstock; H2 = Max hohe

EUROCASSONETTO FRAMELESS TOP

UN'ANTA CARTONGESSO • ONE DOOR DRYWALL
 UMA PORTA GESSO ACARTONADO • À UN VANTAIL PLACOPLÂTRE
 UNA HOJA YESO LAMINADO • EINEM FLÜGEL GIPSKARTON
 один Створки гипсокартон

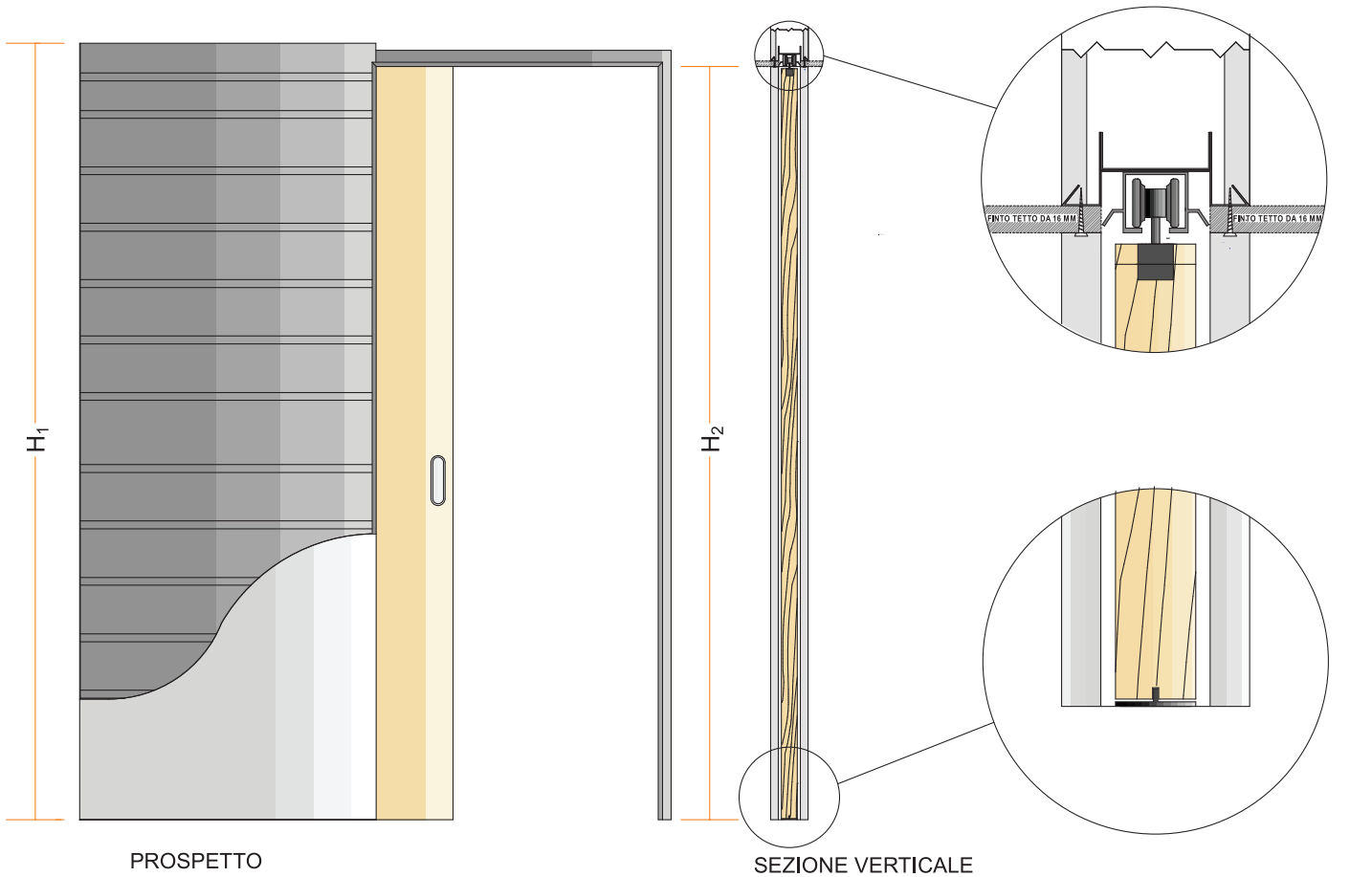

PROSPETTO

SEZIONE VERTICALE

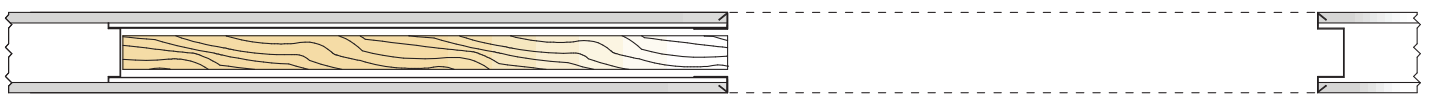

SEZIONE ORIZZONTALE

PROSPETTO • VIEW • PROSPECTO • VUE • VISTA • SCHNITT • Вид

SEZIONE VERTICALE • VERTICAL SECTION • SEÇÃO VERTICAL • COUPE VERTICALE • SECCIÓN VERTICAL • VERTIKAL SCHNITT • ВЕРТИКАЛЬНЫЙ РАЗДЕЛ

SEZIONE ORIZZONTALE • HORIZONTAL SECTION • SEÇÃO HORIZONTAL • COUPE HORIZONTALE • SECCIÓN HORIZONTAL • HORIZONTALER SCHNITT • ГОРИЗОНТАЛЬНЫЙ РАЗДЕЛ

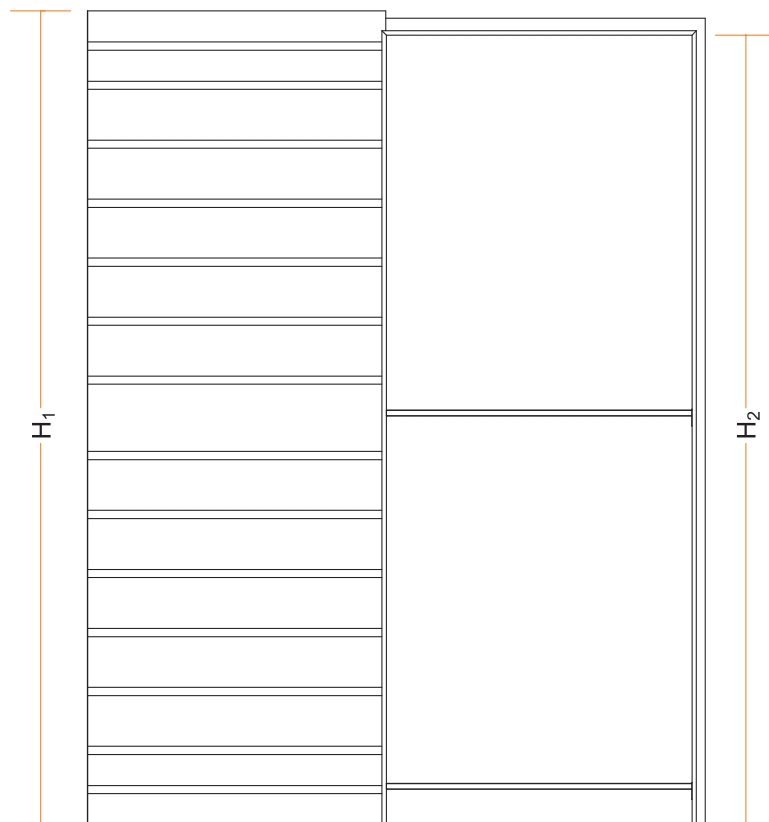

PROSPETTO

S_e	S_i
100	62

S_e = Spessore Parete Finita
 S_i = Sede interna

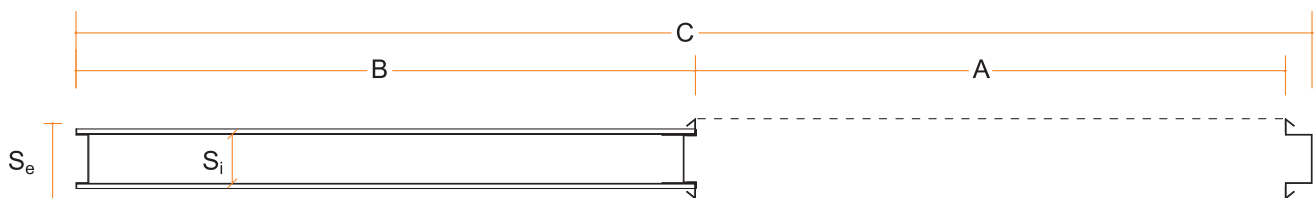

SEZIONE ORIZZONTALE

COD.	A	B	C	H_1	H_2	Misura porta LxH
E 60x230/240/250 FR T CTG. (S_e)	590	630	1255	2375/2475/2575	2310/2410/2510	610x2300/2400/2500
E 70x230/240/250 FR T CTG. (S_e)	690	730	1455	2375/2475/2575	2310/2410/2510	710x2300/2400/2500
E 80x230/240/250 FR T CTG. (S_e)	790	830	1655	2375/2475/2575	2310/2410/2510	810x2300/2400/2500
E 90x230/240/250 FR T CTG. (S_e)	890	930	1855	2375/2475/2575	2310/2410/2510	910x2300/2400/2500
E 100x230/240/250 FR T CTG. (S_e)	990	1030	2055	2375/2475/2575	2310/2410/2510	1010x2300/2400/2500
E 110x230/240/250 FR T CTG. (S_e)	1090	1130	2255	2375/2475/2575	2310/2410/2510	1110x2300/2400/2500
E 120x230/240/250 FR T CTG. (S_e)	1190	1230	2455	2375/2475/2575	2310/2410/2510	1210x2300/2400/2500

Se = Spessore parete finita • Total thickness • Espesura parede acabada • Épaisseur totale • Espesor total • Gesamtstärke • ВСЕГО ТОЛЩИНА СТЕНЫ

Si = sede interna • Internal housing • Parte interna • Logement intérieur • Sede interior • Sitz innen • ВНУТРЕННИЙ ЖИЛЬЕ

PROSPETTO • VIEW • ПРОСПЕКТ • VUE • VISTA • SCHNITT • Вид

SEZIONE ORIZZONTALE • HORIZONTAL SECTION • SEÇÃO HORIZONTAL • COUPE HORIZONTAL • SECCIÓN HORIZONTAL • HORIZONTALER SCHNITT • ГОРИЗОНТАЛЬНЫЙ РАЗДЕЛ

A = Luce lorda; **B** = Larghezza controtelaio; **C** = Larghezza complessiva; **H1** = Altezza controtelaio; **H2** = Altezza lorda

A = Total Light; B = Counterframe Width; C = Total Width; H1 = Counterframe Height; H2 = Total Height

A = Abertura Bruta; B = Largura Caixa; C = Largura Total; H1 = Altura Caixa; H2 = Altura Bruta;

A = Largeur ouverture brute; B = Largeur contre-châssis; C = Largeur totale; H1 = Hauteur contre-châssis; H2 = Hauteur brute;

A = Sección tránsito bruta; B = Ancho contramarco; C = Ancho total; H1 = Altura contramarco; H2 = Altura bruta;

A = Max ausmaße; B = Breite Blindstock; C = Gesamtbreite; H1 = Höhe Blindstock; H2 = Max hohe

EUROCASSONETTO FRAMELESS TOP

DOPPIO CARTONGESSO • DOUBLE DRYWALL

DUPLO GESSO ACARTONADO

DOUBLE PLACOPLÂTRE

DOBLE YESO LAMINADO

DOPPELTEN GIPSKARTON

двойной гипсокартон

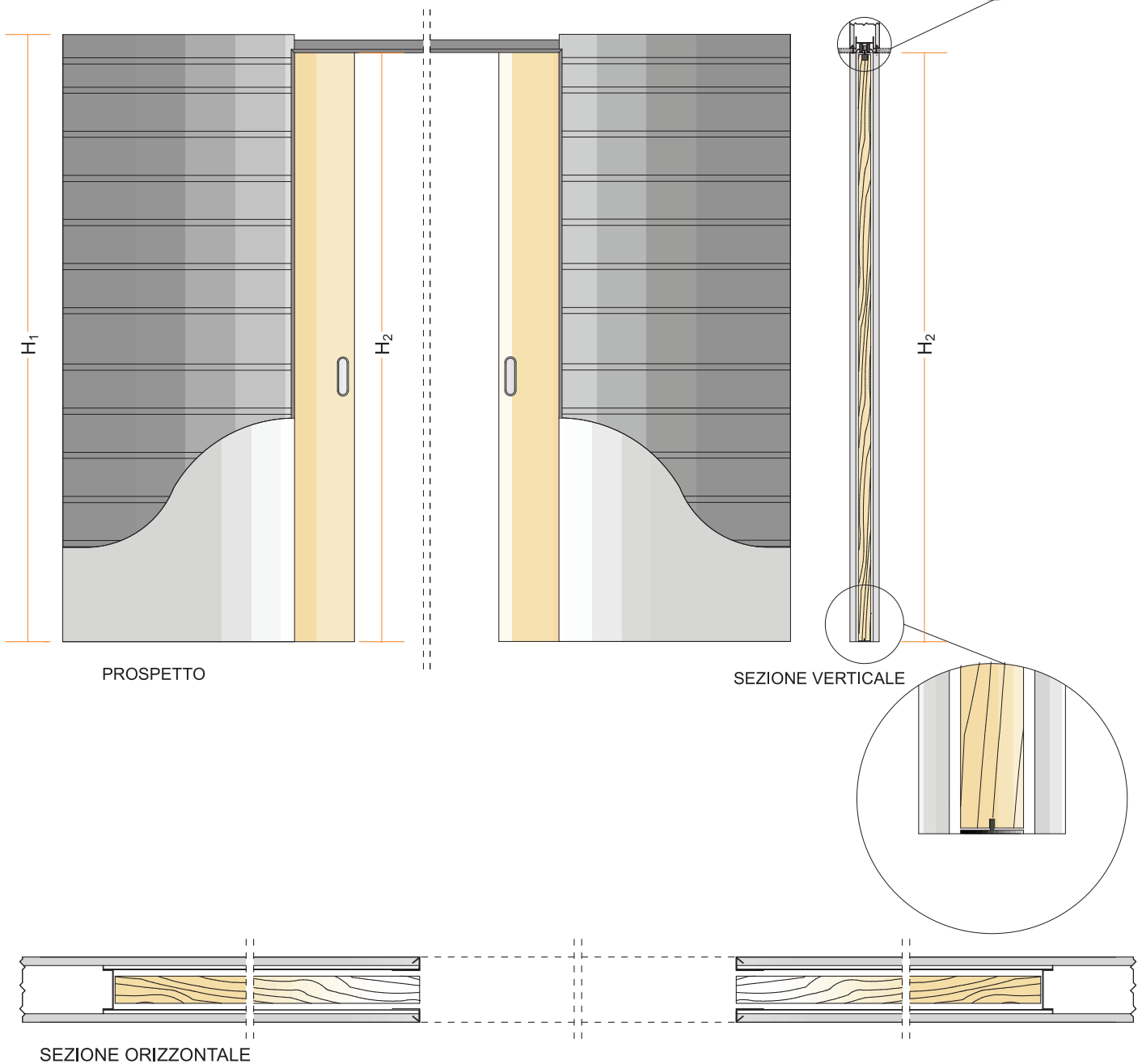

PROSPETTO • VIEW • PROSPECTO • VUE • VISTA • SCHNITT • Вид

SEZIONE VERTICALE • VERTICAL SECTION • SEÇÃO VERTICAL • COUPE VERTICALE • SECCIÓN VERTICAL • VERTIKAL SCHNITT • ВЕРТИКАЛЬНЫЙ РАЗДЕЛ

SEZIONE ORIZZONTALE • HORIZONTAL SECTION • SEÇÃO HORIZONTAL • COUPE HORIZONTAL • SECCIÓN HORIZONTAL • HORIZONTALER SCHNITT • ГОРИЗОНТАЛЬНЫЙ РАЗДЕЛ

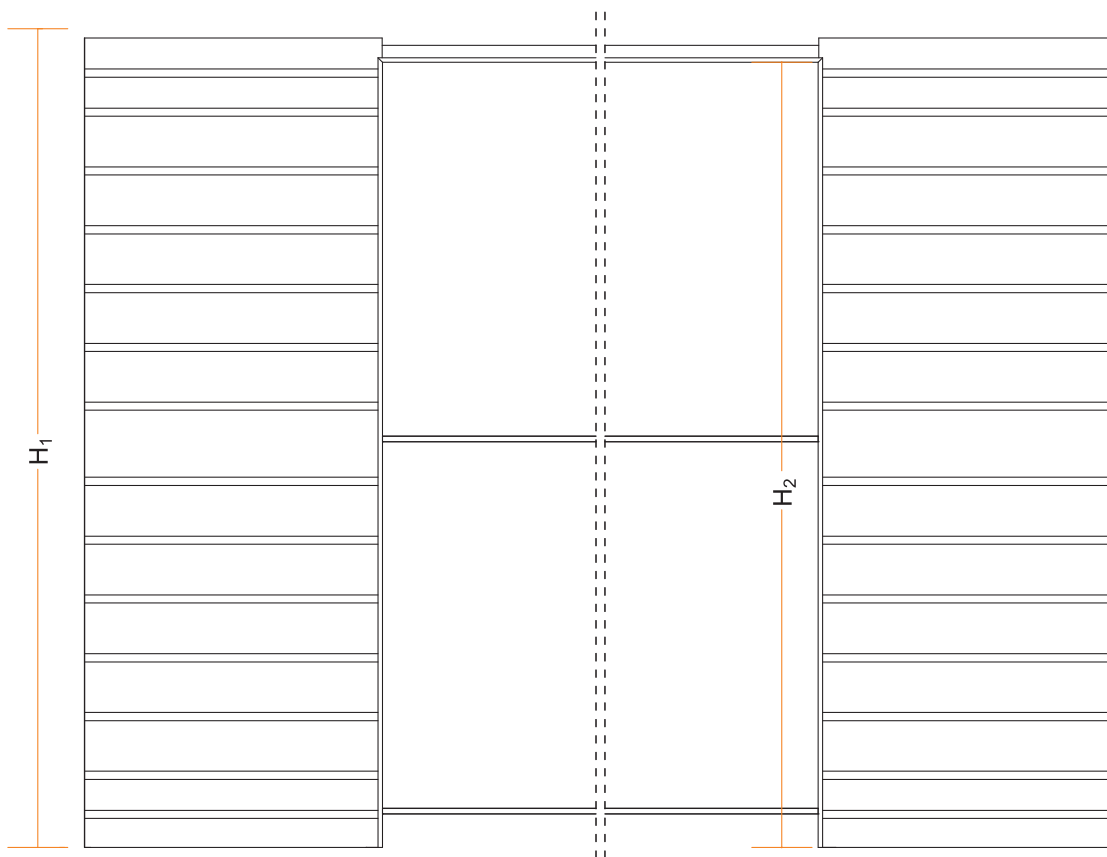

PROSPETTO

S_e	S_i
100	62

S_e = Spessore Parete Finita
 S_i = Sede interna

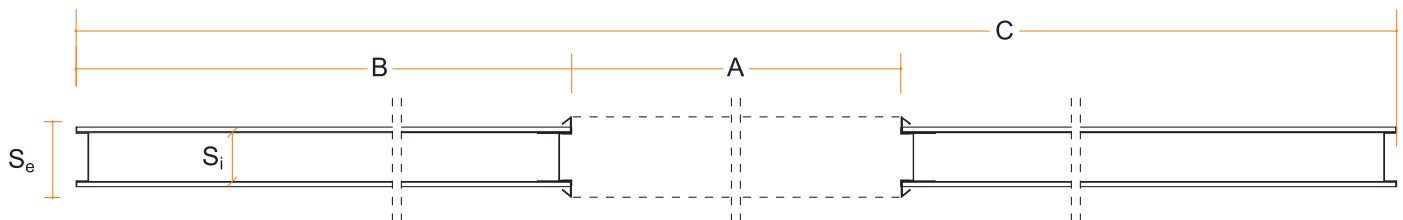

SEZIONE ORIZZONTALE

COD.	A	B	C	H ₁	H ₂	Misura porta LxH
E 60x230/240/250 FR T D CTG.(S_e)	1190	630	2450	2365/2465/2565	2310/2410/2510	N°2 610x2300/2400/2500
E 70x230/240/250 FR T D CTG.(S_e)	1390	730	2850	2365/2465/2565	2310/2410/2510	N°2 710x2300/2400/2500
E 80x230/240/250 FR T D CTG.(S_e)	1590	830	3250	2365/2465/2565	2310/2410/2510	N°2 810x2300/2400/2500
E90x230/240/250 FR T D CTG.(S_e)	1790	930	3650	2365/2465/2565	2310/2410/2510	N°2 910x2300/2400/2500
E100x230/240/250 FR T D CTG.(S_e)	1990	1030	4050	2365/2465/2565	2310/2410/2510	N°2 1010x2300/2400/2500
E110x230/240/250 FR T D CTG.(S_e)	2190	1130	4450	2365/2465/2565	2310/2410/2510	N°2 1110x2300/2400/2500
E120x230/240/250 FR T D CTG.(S_e)	2390	1230	4850	2365/2465/2565	2310/2410/2510	N°2 1210x2300/2400/2500

Se = Spessore parete finita • Total thickness • Espesura parede acabada • Épaisseur totale • Espesor total • Gesamtstärke • ВСЕГО ТОЛЩИНА СТЕНЫ

Si = sede interna • Internal housing • Parte interna • Logement intérieur • Sede interior • Sitz innen • ВНУТРЕННИЙ ЖИЛЬЕ

PROSPETTO • VIEW • ПРОСПЕКТ • VUE • VISTA • SCHNITT • Вид

SEZIONE ORIZZONTALE • HORIZONTAL SECTION • SEÇÃO HORIZONTAL • COUPE HORIZONTAL • SECCIÓN HORIZONTAL • HORIZONTALER SCHNITT • ГОРИЗОНТАЛЬНЫЙ РАЗДЕЛ

A = Luce lorda; **B** = Larghezza controtelaio; **C** = Larghezza complessiva; **H₁** = Altezza controtelaio; **H₂** = Altezza lorda

A = Total Light; B = Counterframe Width; C = Total Width; H₁ = Counterframe Height; H₂ = Total Height

A = Abertura Bruta; B = Largura Caixilho; C = Largura Total; H₁ = Altura Caixilho; H₂ = Altura Bruta;

A = Largeur ouverture brute; B = Largeur contre-châssis; C = Largeur totale; H₁ = Hauteur contre-châssis; H₂ = Hauteur brute;

A = Sección tránsito bruta; B = Ancho contromarco; C = Ancho total; H₁ = Altura contromarco; H₂ = Altura bruta;

A = Max ausmaße; B = Breite Blindstock; C = Gesamtbreite; H₁ = Hohe Blindstock; H₂ = Max hohe

ORO

 "Oro" è il controtelaio che unisce la tecnica e la sobrietà. Pensato e realizzato esclusivamente per accogliere porte in vetro e al contempo per offrire una soluzione minimalista e sofisticata. Il tutto si traduce in una soluzione elegante per grandi e piccoli ambienti. Nota tecnica: disponibile solamente nello spessore 105 mm per pareti in intonaco.

 "Oro" is our counter-frame for concealed sliding doors that combines technology and plain lines. Designed and built exclusively to accommodate glass doors while offering a minimalist and sleek solution. All of which translates into an elegant solution for large and small settings. Technical note: only available in 105 mm thickness for plaster walls.

 "Oro" é o caixilho para portas de correr retráteis que une a técnica à sobriedade. Pensado e criado exclusivamente para portas de correr de vidro e, ao mesmo tempo, para oferecer uma solução minimalista e sofisticada. Tudo isso se traduz numa solução elegante para ambientes grandes e pequenos. Nota técnica: disponível apenas com espessura de 105 mm para paredes de reboco.

 «Oro», c'est le contre-châssis pour portes coulissantes à galandage qui allie la technique et la sobriété. Conçu et réalisé exclusivement pour accueillir à la fois les portes en verre et offrir une solution minimaliste et sophistiquée. Le tout se traduit par une solution élégante, pour les environnements de grandes et petites dimensions. Précision technique: disponible uniquement en 105 mm d'épaisseur pour les parois en enduit.

 «Oro» es el contramarco para puertas correderas empotradas que une técnica y sobriedad. Pensado y realizado exclusivamente para albergar puertas de cristal y, al mismo tiempo, ofrecer una solución minimalista y sofisticada. Todo ello se traduce en una solución elegante para ambientes tanto grandes como pequeños. Nota técnica: disponible solo con un grosor de 105 mm para paredes con enlucido.

 "Oro" ist der Gegenrahmen für Schiebetüren, der Technik und Schlichtheit vereint. Er wurde ausschließlich für Glastüren entwickelt und gebaut, um gleichzeitig eine minimalistische und raffinierte Lösung anzubieten. All dies führt zu einer eleganten Lösung für große und kleine Räume. Technischer Hinweis: Nur in der Stärke 105 mm für verputzte Wände erhältlich.

 "Ого" - кассета для раздвижных убирающихся дверей, объединяющая в себе техничность и сдержанность стиля. Она предназначена исключительно для стеклянных дверей, одновременно обеспечивая минималистичное изысканное решение дизайна. В совокупности это становится элегантным вариантом декора для больших и маленьких помещений. Техническое примечание: выпускается только толщиной 105 мм для оштукатуренных стен.



EUROCASSONETTO ORO

UN'ANTA INTONACO • ONE DOOR PLASTER • UMA PORTA REBOCO
 À UN VANTAIL ENDUIT • UNA HOJA ENLUCIDO • EINEM FLÜGEL PUTZ
 один Створки штукатурку

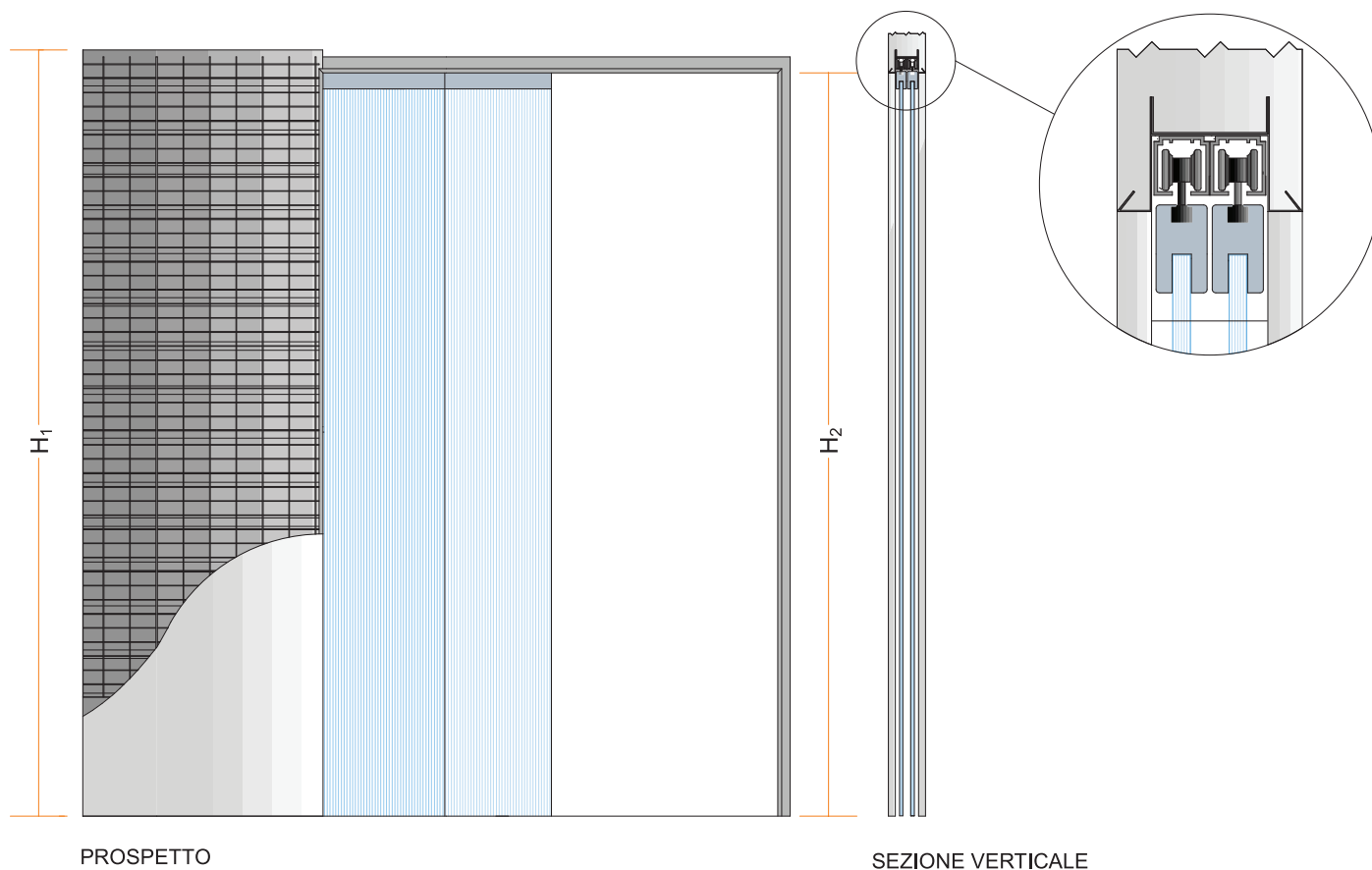

SEZIONE ORIZZONTALE

PROSPETTO • VIEW • PROSPECTO • VUE • VISTA • SCHNITT • Вид

SEZIONE VERTICALE • VERTICAL SECTION • SEÇÃO VERTICAL • COUPE VERTICALE • SECCIÓN VERTICAL • VERTIKAL SCHNITT • ВЕРТИКАЛЬНЫЙ РАЗДЕЛ

SEZIONE ORIZZONTALE • HORIZONTAL SECTION • SEÇÃO HORIZONTAL • COUPE HORIZONTALE • SECCIÓN HORIZONTAL • HORIZONTALER SCHNITT • ГОРИЗОНТАЛЬНЫЙ РАЗДЕЛ

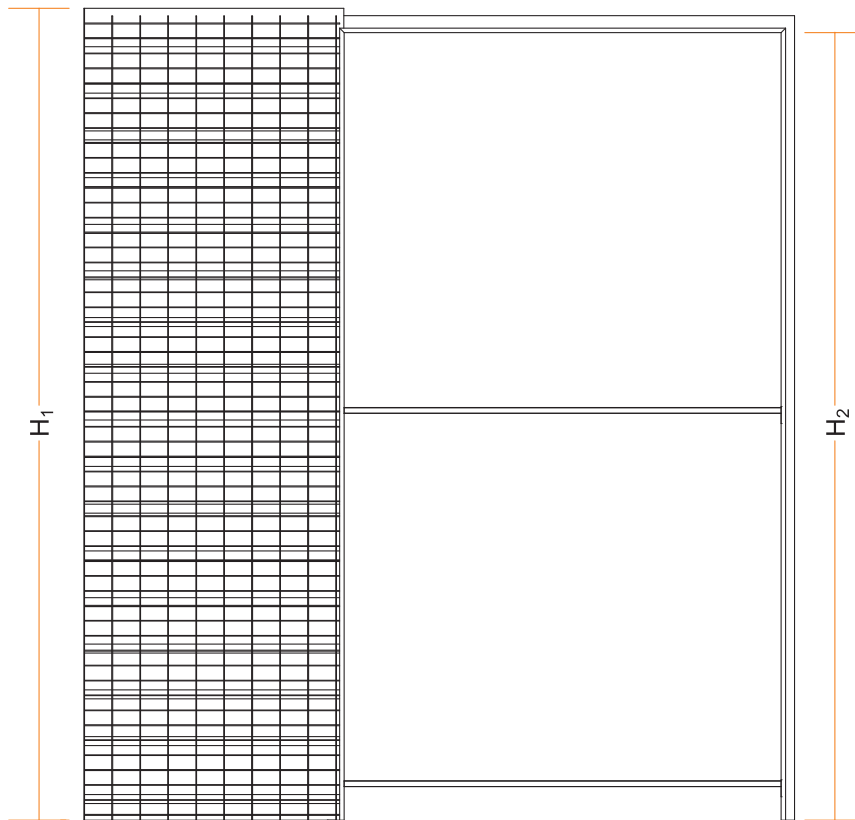

S_e	S_i
105	69

S_e = Spessore Parete Finita
 S_i = Sede interna

PROSPETTO

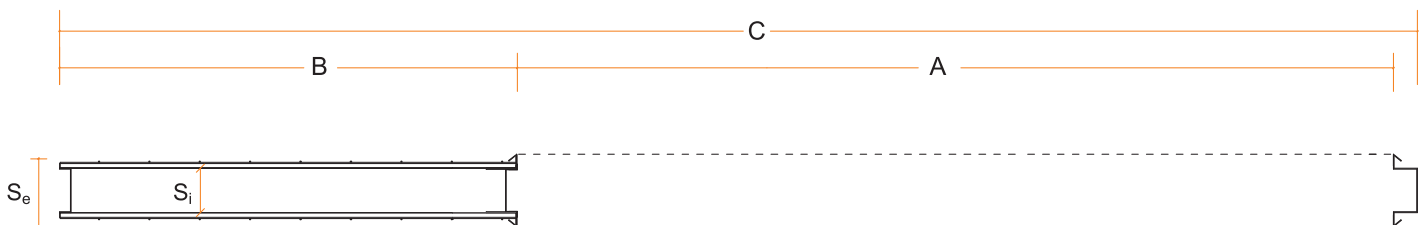

SEZIONE ORIZZONTALE

COD.	A	B	C	H ₁	H ₂	Misura porta LxH
E 60x210/200/202 OR INT.(S_e)	1190	650	1875	2175/2075/2095	2110/2010/2030	630x2100/2000/2020
E 70x210/200/202 OR INT.(S_e)	1390	750	2175	2175/2075/2095	2110/2010/2030	730x2100/2000/2020
E 80x210/200/202 OR INT.(S_e)	1590	850	2475	2175/2075/2095	2110/2010/2030	830x2100/2000/2020
E 90x210/200/202 OR INT.(S_e)	1790	950	2775	2175/2075/2095	2110/2010/2030	930x2100/2000/2020
E 100x210/200/202 OR INT.(S_e)	1990	1050	3075	2175/2075/2095	2110/2010/2030	1030x2100/2000/2020
E 110x210/200/202 OR INT.(S_e)	2190	1150	3375	2175/2075/2095	2110/2010/2030	1130x2100/2000/2020
E 120x210/200/202 OR INT.(S_e)	2390	1250	3675	2175/2075/2095	2110/2010/2030	1230x2100/2000/2020

Se = Spessore parete finita • Total thickness • Espesura parede acabada • Épaisseur totale • Espesor total • Gesamtstärke • ВСЕГО ТОЛЩИНА СТЕНЫ

Si = sede interna • Internal housing • Parte interna • Logement intérieur • Sede interior • Sitz innen • ВНУТРЕННИЙ ЖИЛЬЕ

PROSPETTO • VIEW • ПРОСПЕКТ • VUE • VISTA • SCHNITT • Вид

SEZIONE ORIZZONTALE • HORIZONTAL SECTION • SEÇÃO HORIZONTAL • COUPE HORIZONTALE • SECCIÓN HORIZONTAL • HORIZONTALER SCHNITT • ГОРИЗОНТАЛЬНЫЙ РАЗДЕЛ

A = Luce lorda; B = Larghezza controtelaio; C = Larghezza complessiva; H1 = Altezza controtelaio; H2 = Altezza lorda

A = Total Light; B = Counterframe Width; C = Total Width; H1 = Counterframe Height; H2 = Total Height

A = Abertura Bruta; B = Largura Caixa; C = Largura Total; H1 = Altura Caixa; H2 = Altura Bruta;

A = Largeur ouverture brute; B = Largeur contre-châssis; C = Largeur totale; H1 = Hauteur contre-châssis; H2 = Hauteur brute;

A = Sección tránsito bruta; B = Ancho contramarco; C = Ancho total; H1 = Altura contramarco; H2 = Altura bruta;

A = Max ausmaße; B = Breite Blindstock; C = Gesamtbreite; H1 = Hohe Blindstock; H2 = Max hohe

EUROCASSONETTO ORO

DOPPIO INTONACO • DOUBLE PLASTER
 DUPLO REBOCO • DOUBLE ENDUIT
 DOBLE ENLUCIDO • DOPPELTEN PUTZ
 двойной штукатурку

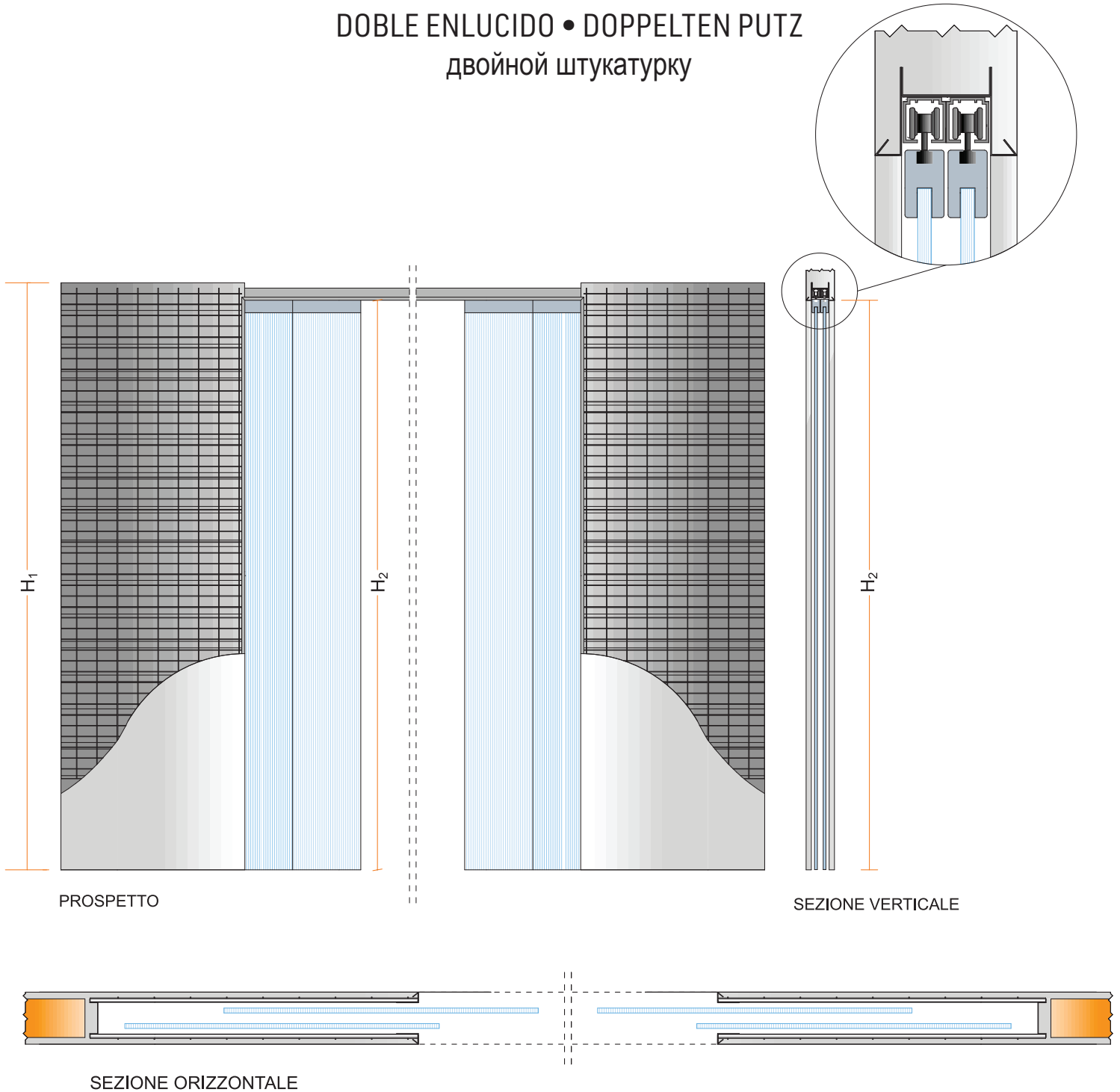

PROSPETTO • VIEW • PROSPECTO • VUE • VISTA • SCHNITT • Вид

SEZIONE VERTICALE • VERTICAL SECTION • SEÇÃO VERTICAL • COUPE VERTICALE • SECCIÓN VERTICAL • VERTIKAL SCHNITT • ВЕРТИКАЛЬНЫЙ РАЗДЕЛ

SEZIONE ORIZZONTALE • HORIZONTAL SECTION • SEÇÃO HORIZONTAL • COUPE HORIZONTALE • SECCIÓN HORIZONTAL • HORIZONTALER SCHNITT • ГОРИЗОНТАЛЬНЫЙ РАЗДЕЛ

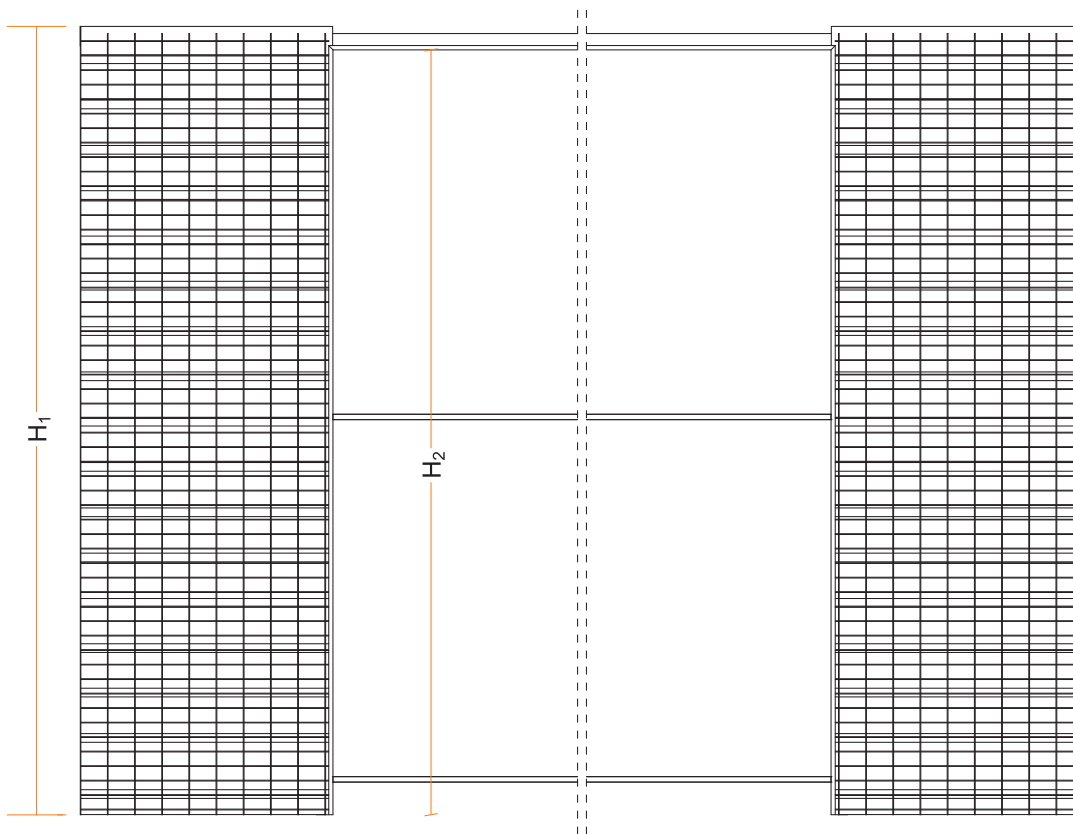

S_e	S_i
105	69

S_e = Spessore Parete Finita
 S_i = Sede interna

PROSPETTO

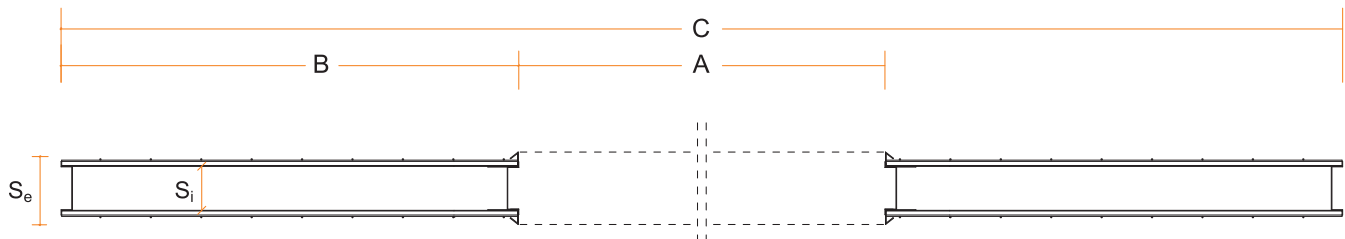

SEZIONE ORIZZONTALE

COD.	A	B	C	H ₁	H ₂	Misura porta LxH
E 60x210/200/202 OR D INT. (S_e)	2390	650	3690	2175/2075/2095	2110/2010/2030	630x2100/2000/2020
E 70x210/200/202 OR D INT. (S_e)	2790	750	4290	2175/2075/2095	2110/2010/2030	730x2100/2000/2020
E 80x210/200/202 OR D INT. (S_e)	3190	850	4890	2175/2075/2095	2110/2010/2030	830x2100/2000/2020
E 90x210/200/202 OR D INT. (S_e)	3590	950	5490	2175/2075/2095	2110/2010/2030	930x2100/2000/2020
E 100x210/200/202 OR D INT. (S_e)	3990	1050	6090	2175/2075/2095	2110/2010/2030	1030x2100/2000/2020
E 110x210/200/202 OR D INT. (S_e)	4390	1150	6690	2175/2075/2095	2110/2010/2030	1130x2100/2000/2020
E 120x210/200/202 OR D INT. (S_e)	4790	1250	7290	2175/2075/2095	2110/2010/2030	1230x2100/2000/2020

Se = Spessore parete finita • Total thickness • Espesura parede acabada • Épaisseur totale • Espesor total • Gesamtstärke • ВСЕГО ТОЛЩИНА СТЕНЫ

Si = sede interna • Internal housing • Parte interna • Logement intérieur • Sede interior • Sitz innen • ВНУТРЕННИЙ ЖИЛЬЕ

PROSPETTO • VIEW • ПРОСПЕКТ • VUE • VISTA • SCHNITT • Вид

SEZIONE ORIZZONTALE • HORIZONTAL SECTION • SEÇÃO HORIZONTAL • COUPE HORIZONTAL • SECCIÓN HORIZONTAL • HORIZONTALER SCHNITT • ГОРИЗОНТАЛЬНЫЙ РАЗДЕЛ

A = Luce lorda; B = Larghezza controtelaio; C = Larghezza complessiva; H1 = Altezza controtelaio; H2 = Altezza lorda

A = Total Light; B = Counterframe Width; C = Total Width; H1 = Counterframe Height; H2 = Total Height

A = Abertura Bruta; B = Largura Caixilho; C = Largura Total; H1 = Altura Caixilho; H2 = Altura Bruta;

A = Largeur ouverture brute; B = Largeur contre-châssis; C = Largeur totale; H1 = Hauteur contre-châssis; H2 = Hauteur brute;

A = Sección tránsito bruta; B = Ancho contromarco; C = Ancho total; H1 = Altura contromarco; H2 = Altura bruta;

A = Max ausmaße; B = Breite Blindstock; C = Gesamtbreite; H1 = Hohe Blindstock; H2 = Max hohe

 Il sistema a porta a battente "FILO" di Eurocassonetto è la soluzione corretta per le attuali e moderne tendenze di design e arredamento. Priva di orpelli e fronzoli, la porta, in questo modo, diventa totalmente invisibile. Nota tecnica: la porta viene fornita completa di telaio, serratura e cerniere. Su richiesta disponibile anche in misure fuori standard. Il pannello porta è disponibile in varie colorazioni e in finitura in primer in modo da essere verniciabile a proprio gusto o esattamente dello stesso colore della parete.

 The "FILO" swing door system by Eurocassonetto is the right solution for current and modern design and furnishing trends. Since it has no frills or embellishments, the door becomes totally invisible. Technical note: the door is supplied complete with a frame, lock and hinges. Also available in non-standard sizes, on request. The door panel is available in various colours and in a primer finish so it can be painted to your taste or can be painted to match the exact colour of the wall.

 O sistema de porta oscilante "FILO" da Eurocassonetto é a solução certa para as tendências actuais e modernas de design e decoração. Sem ornamentos e adornos, a porta torna-se, desta forma, totalmente invisível. Nota técnica: a porta é fornecida com caixilho, fechadura e dobradiças. A pedido também disponível em tamanhos personalizados. O painel da porta está disponível em várias cores e acabamentos em primer de modo a poder ser envernizada ao seu gosto ou exactamente da mesma cor que a parede.

 Le système de porte battante « FILO » d'Eurocassonetto est la solution idéale pour suivre les tendances de design et d'ameublement actuelles et modernes. Dénuée d'accessoires, la porte devient ainsi totalement invisible. Remarque technique : la porte est livrée avec un châssis, une serrure et des charnières. Sur demande, elle est aussi disponible dans des mesures non standard. Le panneau de porte est disponible dans plusieurs couleurs et finitions d'enduit, afin d'être peint à votre goût ou de la même couleur que les murs.

 El sistema de puerta a batiente «FILO» de Eurocassonetto es la solución perfecta para las tendencias actuales y modernas de diseño y decoración. Al estar desprovistas de adornos y ornamentos, las puertas se hacen invisibles. Nota técnica: la puerta incluye marco, cerradura y bisagras. Si lo solicita, también está disponible en medidas no estándares. El panel de la puerta está disponible en varios colores y en acabado de imprimación para poder barnizarlo al gusto o exactamente del mismo color que la pared.

 Das Pendeltürsystem "FILO" von Eurocassonetto ist die richtige Lösung für aktuelle und moderne Design- und Einrichtungstrends. Ohne Schnickschnack wird die Tür auf diese Weise völlig unsichtbar. Technischer Hinweis: Die Tür wird komplett mit Rahmen, Schloss und Scharnieren geliefert. Auf Anfrage auch in Sondergrößen erhältlich. Das Türblatt ist in verschiedenen Farben und in einer Grundierung erhältlich, so dass es nach Ihrem Geschmack oder exakt in der gleichen Farbe wie die Wand lackiert werden kann.

 Система распашной двери "FILO" Eurocassonetto - правильный выбор для актуальных современных решений дизайна и обстановки. При этом дверь, не имеющая декоративных элементов, становится абсолютно невидимой. Техническое примечание: дверь поставляется с коробкой, замком и петлями. На заказ выполняются также нестандартные размеры. Дверное полотно выпускается различных цветов и с покрытием грунтовкой для окраски по своему желанию или точно в цвет стены.



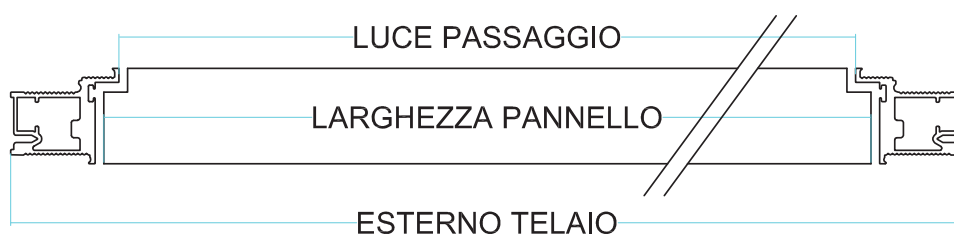

LUCE PASSAGGIO • PASSAGE LIGHT • LUZ DE PASSAGEM
 LARGEUR DE PASSAGE • ANCHO DE TRÁNSITO • DURCHGANGSBREITE

LARGHEZZA PANNELLO • DOOR WIDTH • LARGURA PORTA
 LARGEUR PORTE • ANCHO PUERTA • TÜRBREITE

LARGHEZZA TOTALE • TOTAL WIDTH • LARGURA TOTAL
 LARGEUR TOTALE • ANCHO TOTAL • GESAMTBREITE

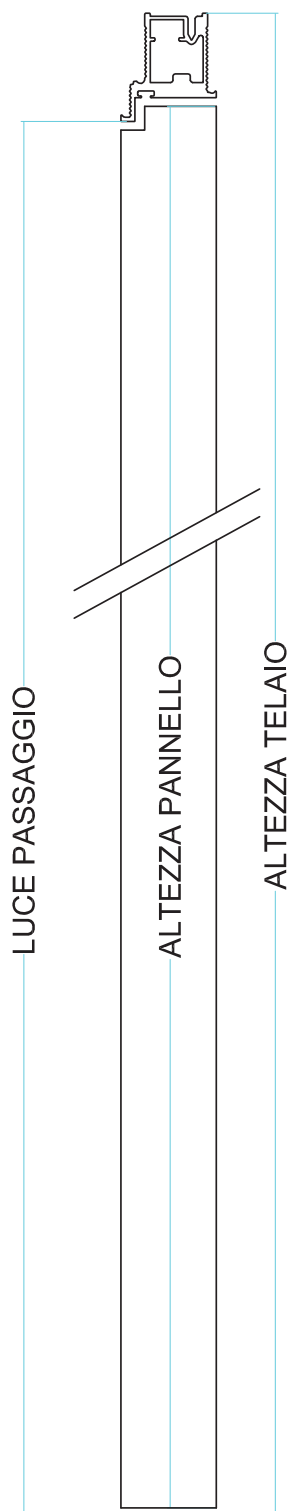

LUCE PASSAGGIO • PASSAGE LIGHT • LUZ DE PASSAGEM
 HAUTEUR DE PASSAGE • ALTURA DE TRÁNSITO • DURCHGANGSBREITE

ALTEZZA PANNELLO • DOOR HEIGHT • ALTURA PORTA
 HAUTEUR PORTE • ALTURA PUERTA • TÜRHÖHE

ALTEZZA TOTALE • TOTAL HEIGHT • ALTURA TOTAL
 HAUTEUR TOTALE • ALTURA TOTAL • GESAMTHÖHE

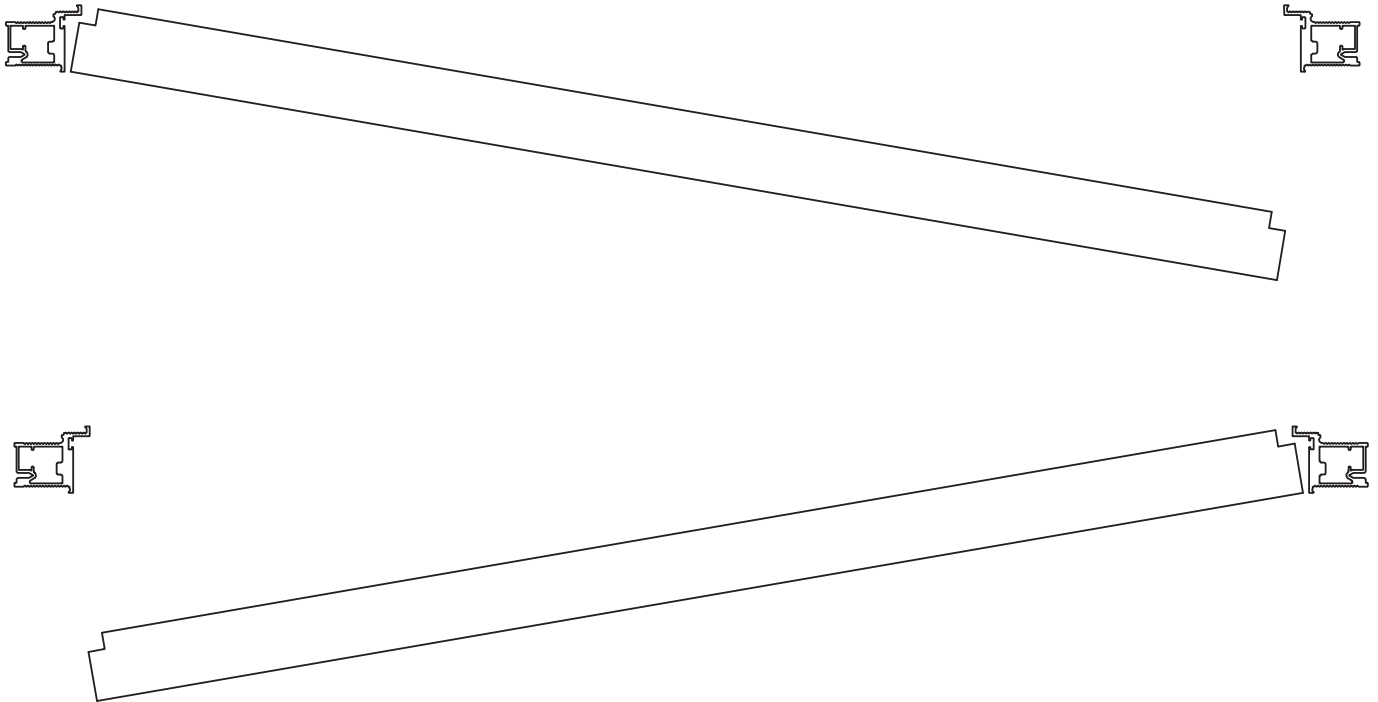

LARGHEZZA ESTERNA TELAIO (in mm)	LUCE PASSAGGIO IN LARGHEZZA (in mm)	LARGHEZZA PANNELLO (in mm)	ALTEZZA ESTERNO TELAIO (in mm)	LUCE PASSAGGIO IN ALTEZZA (in mm)	ALTEZZA PANNELLO (in mm)
698	598	613	2150	2100	2102
798	698	713	2150	2100	2102
898	798	813	2150	2100	2102
998	898	913	2150	2100	2102
1098	998	1013	2150	2100	2102

LARGHEZZA ESTERNA TELAIO

TOTAL WIDTH
LARGURA TOTAL
LARGEUR TOTALE
ANCHO TOTAL
GESAMTBREITE

LUCE PASSAGGIO IN LARGHEZZA

PASSAGE LIGHT (WIDTH)
LUZ DE PASSAGEM (LARGURA)
LARGEUR DE PASSAGE
ANCHO DE TRÁNSITO
DURCHGANGSBREITE

LARGHEZZA PANNELLO

DOOR WIDTH
LARGURA PORTA
LARGEUR PORTE
ANCHO PUERTA
TÜRBREITE

ALTEZZA ESTERNO TELAIO

TOTAL HEIGHT
ALTURA TOTAL
HAUTEUR TOTALE
ALTURA TOTAL
GESAMTHÖHE

LUCE PASSAGGIO IN ALTEZZA

PASSAGE LIGHT (HEIGHT)
LUZ DE PASSAGEM (ALTURA)
HAUTEUR DE PASSAGE
ALTURA DE TRÁNSITO
DURCHGANGSBREITE

ALTEZZA PANNELLO

DOOR HEIGHT
ALTURA PORTA
HAUTEUR PORTE
ALTURA PUERTA
TÜRHOHE

ALUMINIUM **BINARIO ESTERNO**



Il binario in alluminio esterno muro rappresenta la soluzione in chiave moderna della porta scorrevole esterno parete in accordo con interni e arredamenti dal gusto più contemporaneo.

Nota tecnica: il binario in estruso di alluminio è un unico blocco con il copri binario, anch'esso in alluminio.

Disponibile nella versione satinata e in vari colori.

Misure disponibili: 150/180/200/250 cm



The aluminium external wall track is a modern solution for external sliding doors that goes well with contemporary interiors and furnishings.

Technical note: the extruded aluminium track is a single block with a track cover and is also made of aluminium.

Available in satin and various colours.

Available sizes: 150/180/200/250 cm



O binário externo em alumínio de parede, representa a solução moderna de uma porta de correr externa que combina com decoração de interiores de gosto contemporâneo.

Nota técnica: o binário de alumínio extrudido é um bloco único com a tampa do binário também em alumínio.

Disponível na versão acetinada e em várias cores.

Medidas Disponíveis: 150/180/200/250 cm



Les rails en aluminium extérieurs au mur représentent la solution réactualisée de la porte coulissante à sur un mur, en accord avec un style d'intérieur et d'ameublement plus contemporain.

Remarque technique : les rails en aluminium extrudé sont faits d'un seul et unique tenant avec le cache-rails, lui aussi en aluminium.

Disponibile en version mate et dans différentes couleurs.

Mesures disponibles: 150/180/200/250 cm



El riel de aluminio externo a la pared representa la solución en clave moderna de las puertas correderas que van por el exterior de la pared, de acuerdo con los interiores y decoración del gusto más contemporáneo.

Nota técnica: el riel de aluminio extrudido forma un único bloque con el cubrerrieles, también de aluminio.

Disponibile en la versión satinada y en varios colores.

Medidas disponibles: 150/180/200/250 cm



Die Aluminium-Außenwandschiene repräsentiert die moderne Lösung der Außenschiebetür im Einklang mit moderneren Innenräumen und Möbeln.

Technischer Hinweis: Die extrudierte Aluminiumschiene ist ein einzelner Block mit der Schienenabdeckung, die ebenfalls aus Aluminium besteht.

Erhältlich in satiniert und verschiedenen Farben.

Verfügbare Größen: 150/180/200/250 cm



Наружная настенная направляющая из алюминия представляет собой современное решение раздвижной двери-купе, согласующееся с самыми современными интерьерами и обстановкой.

Техническое примечание: направляющая из экструдированного алюминиевого профиля образует единое целое с крышкой направляющей, также выполненной из алюминия.

Выпускается в сатиновом варианте и разных цветов.

Стандартные размеры: 150/180/200/250 cm





EUROCASSONETTO ALUMINIUM

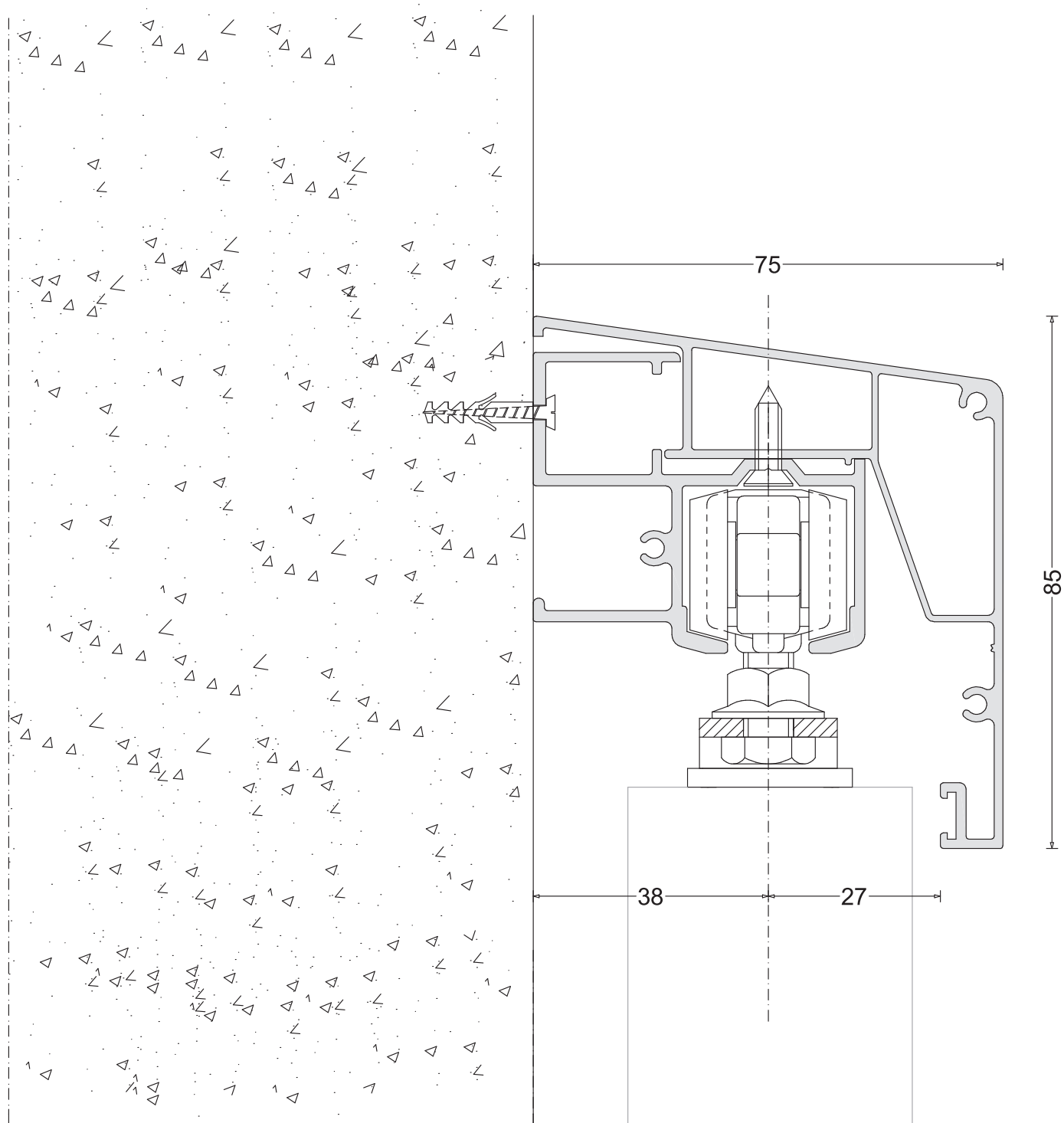

EUROCASSONETTO ALUMINIUM

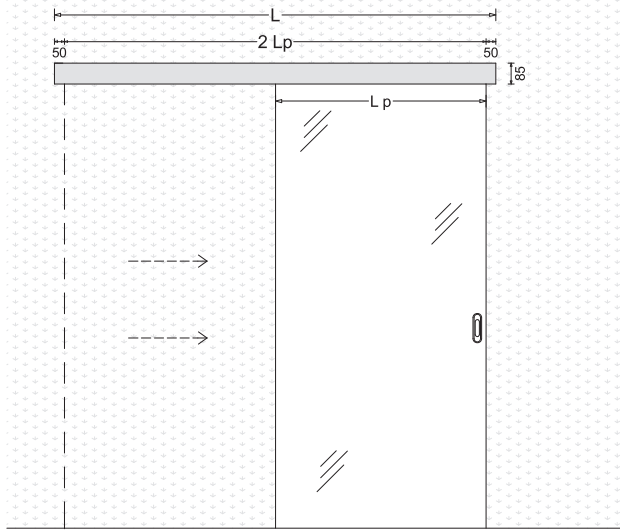

$$L = 2Lp + 100$$

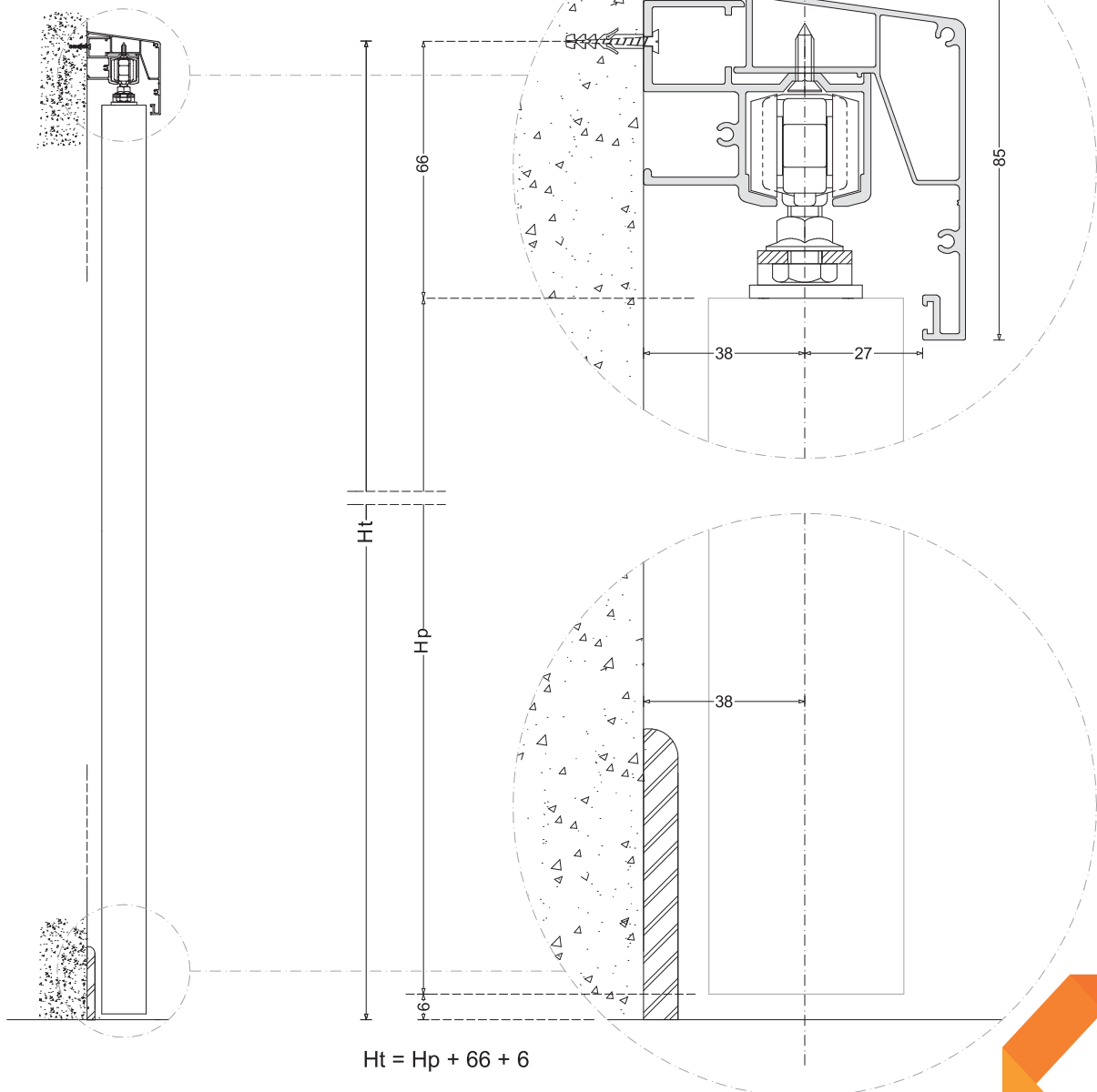

$$Ht = Hp + 66 + 6$$

PRESENTAZIONE

pag. 01

MAGNIFIKO

pag. 02

FRAMELESS TOP

pag. 12

ORO

pag. 22

FILO PORTE A BATTENTE FILOMURO

pag. 28

ALUMINIUM BINARIO ESTERNO

pag. 32





www.eurocassonetto.com

